

Air Motors / Gear Motors

Lubricated and Non-lubricated

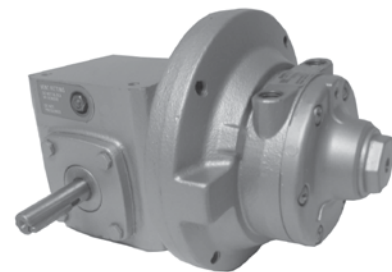
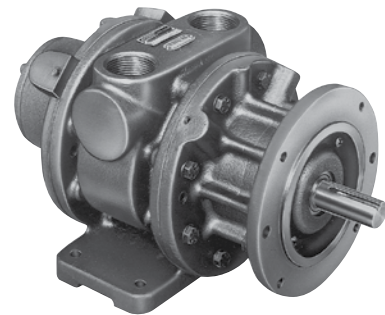
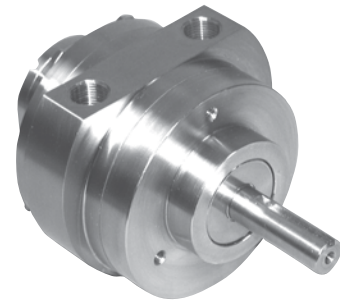

The Gast Group Difference

For over 90 years, Gast Manufacturing has been providing innovative air solutions to a broad breadth of customers. With the relatively recent addition of JUN-AIR, we have expanded our capabilities and formed, "The Gast Group." Together, our diverse engineering background and pneumatic experience allow us to provide both component and system solutions to meet all of your pneumatic needs...all backed by our strong commitment to quality and customer support.

Products for Almost Any Application – Worldwide

We offer an extensive and versatile line of air-moving products, including vacuum pumps, compressors, air motors, gear motors, vacuum generators, and regenerative blowers. We design and build these components for original equipment manufacturers worldwide, but we also develop complete pneumatic solutions to solve tough customer challenges.

To ensure fast, efficient delivery of products, Gast has a vast network of sales representatives/distributors throughout the United States and the world. Plus, we maintain direct sales and service facilities in Europe, Hong Kong, and Shanghai, China.

Unparalleled Design Expertise

Unlike other manufacturers, who might expect you to modify your pneumatic system to fit their available product(s), Gast is committed to finding the right product to meet your specific needs. If we don't have a high-quality, off-the-shelf product to fit your existing application or meet your anticipated needs, we'll propose customized cost-effective design options that will serve your special requirements. We can even develop and produce your complete pneumatic system for you.

Our experienced Research and Development engineers and Product engineers work together to analyze customer needs and use computer-aided design to generate timely solutions for air-handling problems. The design team has one goal: to create problem-solving solutions that capitalize on the latest available technology, meet all application requirements, and benefit from cost-effective production methods. The end result: products and solutions that are the best value in the marketplace for our customers.

A Lasting Commitment to Quality

We invest heavily in both equipment and people to maintain the consistent quality for which our products are known worldwide, and we have done so since day one. As early as 1983, we implemented a total quality process designed to ensure the quality of our products. In keeping with that tradition, Gast has achieved ISO 9001 certification, making us a member of the elite group of manufacturing companies in the world to receive that certification.

European Community Directives (CE)

With extensive sales outside the United States, Gast has pledged to conform to the European Community Directives. These directives contain essential requirements concerning health, safety, environment, and consumer protection for all products targeted for the European Community market. Currently, all Gast products available for sale in the European Community are in compliance with the Machinery, Low Voltage, and Electromagnetic Compatibility Directives.

Pictorial and dimensional data is subject to change without notice. The information presented is based on technical data and test results of nominal units. It is believed to be accurate and is offered as an aid in the selection of Gast products. It is the user's responsibility to determine suitability of the product for intended use and the user assumes all risk and liability whatsoever in connection therewith. Environmental and application conditions may affect advertised life.

Why use a Gast Air Motor?

Variable Speed

You can vary air motor speed between 300 and 10,000 rpm (depending on model selection) with a simple valve put in between the air source and air motor.

Non-electrical Sparking

As a non-electrical device, the possibility of explosion from igniting flammable gases is greatly reduced.

Instantly Reversible

A four-way valve in the air line enables a Gast Air Motor to be instantly reversed. A turn of the valve causes a complete reversal of rotation, even when the motor is running at full speed.

Cool Running

As the air motor turns, expanded air cools the motor. Units can be used in ambient temperatures up to 250 °F (120 °C) in a non-hazardous atmosphere.

Compact and Portable

Get maximum horsepower with minimum size and weight.

Minimum Maintenance

You can put a Gast Air Motor in places where they will not get much service, because there's virtually nothing to service on a Gast Air Motor, providing it is operated on a clean, dry, and lubricated air supply*.

Will Not Burn Out

Gast Air Motors can be stalled or overloaded for long periods without damage.

Low Price

Cost is less than other motors of equal horsepower and capabilities.

Operate in All Positions

Mount them sideways, upside-down, or in any position so long as adequate lubrication* is provided and end thrust is kept to design limits. Gear Motors will operate in almost any position, see model data.

Low-shock Starts

Because Gast Air Motors go to work with air-cushioned smoothness, they cut stress on your equipment.

Self-sealing Vanes

Vaness are self-sealing and automatically take up their own wear, thus ensuring constant output for thousands of hours of use.

Mounting Flexibility

Foot, hub, face, NEMA-C, or metric flange motor mountings are standard equipment for most air motor sizes.

Four-vane or Eight-vane

Four-vane units meet most requirements, but for more precise inching control and minimum blowby in applications where motor is operating in a stalled condition, specify eight-vane models.

Long-life Accessories

To ensure long life, Gast offers accessories designed to extend unit life including air filters that remove water and particles down to 5 microns, and air line lubricators that supply a constant flow of lubrication automatically*. We can supply a pressure regulator that provides precise control of power and operating speed. Options like these help you get smooth performance with minimum maintenance.

*Non-lubricated series does not require a lubricator

How to Select an Air Motor



Air motors differ in many ways from other power sources. These unique operating characteristics must be considered when selecting an air motor for a particular job. It is easy to change horsepower and speed of an air motor by throttling the air inlet. Therefore, the best rule of thumb for selecting an air motor is to choose

one that will provide the horsepower and torque needed using only two-thirds ($\frac{2}{3}$) of the line pressure available. The full air line pressure will then be available for overloads and starting.

Output Power vs. Speed

The output power of an air motor is relative to speed and to air line pressure.

Torque vs. Speed

1. An air motor slows down when load increases... at the same time its torque increases to a point where it matches the load. It will continue to provide increased torque all the way to the stalled condition, and it can maintain the stalled condition without any harm to the motor.
2. As the load is reduced, an air motor will increase speed and the torque will decrease to match the reduced load.
3. When the load on an air motor is either increased or decreased, speed can be controlled by increasing or decreasing air pressure.
4. Starting torque of an air motor is lower than running torque. While this provides smooth, low-shock starting, it is necessary to have additional air line pressure for starting under heavy loads.

Air Consumption vs. Speed

Air consumption increases as speed and air pressure is increased.

Air Motor/Gear Motor Performance Overview

Whatever your rotary air motor power requirements, chances are we have what you're looking for.

Stainless Steel and Standard Air Motors Specifications

MODEL	OPERATING DATA							MAXIMUM TORQUE		
	MAX. SPEED rpm	OUTPUT POWER		TORQUE		MAX. AIR CONSUMPTION		MAX. SPEED rpm	MAXIMUM TORQUE	
		HP	kW	lb. in.	Nm	cfm	m ³ /h		lb. in.	Nm
STAINLESS STEEL AIR MOTORS										
1AM	10,000	0.45	0,33	2.75	0,31	20.5	35,1	650	5.6	0,65
4AM	3,000	1.70	1,30	36.00	4,1	78	132,5	300	56.00	6,3
6AM	3,000	4.00	3,00	84.00	10,00	128	228	300	115.00	13,00
STANDARD AIR MOTORS										
1AM (A)	10,000	0.45	0,33	2.75	0,31	20.5	35,1	650	5.6	0,65
1UP (B)	6,000	0.45	0,33	5.25	0,58	27	47	500	6.00	0,68
2AM (A)	3,000	0.93	0,68	19.50	2,20	30	49,5	350	26.10	3,05
4AM (A)	3,000	1.70	1,30	36.00	4,1	78	132,5	300	56.00	6,3
6AM (A)	3,000	4.00	3,00	84.00	10,00	128	228	300	115.00	13,00
8AM (A)	2,500	5.25	3,90	132.00	14,40	175	293	300	185.00	21,00
16AM (A)	2,000	9.50	7,10	290.00	34,00	275	475	300	372.00	43,0

Gear Motors Specifications

MODEL	GEAR RATIO	OPERATING DATA								MAXIMUM TORQUE		
		MAX. SPEED rpm	LINE PRES.	OUTPUT POWER		TORQUE		MAX. AIR CONSUMPTION		MAX. SPEED rpm	MAXIMUM TORQUE	
				HP	kW	lb. in.	Nm	cfm	m ³ /h		lb. in.	Nm
Gear MotorS												
1AM-NRV	15:1	350	A	0.34	0,26	62	7,1	21.0	36	30	72	8,1
1UP-NRV	15:1	400	C	0.32	0,23	49	5,5	2	36	30	71	8,0
2AM-43A	20:1	150	C	0.26	0,39	110	12,4	18	30,6	60	145	16,4
2AM-43A	20:1	150	A	0.58	0,43	240	27,1	42	71,4	60	270	30,5
4AM-RV	10:1	300	B	1.26	0,94	274	31,0	57.5	98	30	425	48,0
4AM-RV	15:1	200	B	1.25	0,90	400	45,2	60.0	102	20	640	72,0
4AM-70C	20:1	150	A	1.17	0,87	487	55,0	71.0	120	15	740	83,6
4AM-70C	40:1	75	A	0.95	0,71	800	90,4	71.0	120	7	1255	141,8
4AM-70C	60:1	50	A	0.82	0,61	1040	117,5	71.0	120	5	1640	185,3
6AM-22A	10:1	300	A	3.40	2,54	720	81,4	130.0	221	30	950	107,4
6AM-22A	20:1	150	A	2.65	1,98	1100	124,3	130.0	221	15	1550	175,6
6AM-22A	40:1	75	A	2.10	1,57	1725	194,9	135.0	230	8	2500	282,5
8AM-32A	20:1	125	A	3.70	2,76	1850	209,1	177.0	301	15	2550	288,2
16AM-13	20:1	100	A	6.50	4,85	4175	471,8	275.0	468	15	5175	584,8

A – 100 psig and 7,0 bar line pressure for imperial and metric data, respectively.
 B – 80 psig and 5,5 bar line pressure for imperial and metric data, respectively.
 C – 60 psig and 4,1 bar line pressure for imperial and metric data, respectively.

Catalog Performance Specifications

The specifications listed are that of a unit at sea level with an ambient temperature of 70 °F (21 °C), operating with normal electrical current conditions. The figures stated in this catalog are nominal approximations for models without accessories. Intake filters and exhaust mufflers, and the accumulation of contaminants in them during operation, will decrease the flow of air as well as the achievable pressure.

The units that we list in this catalog are a small portion of what we actually make. Those listed are considered “standard units” and are normally available from stock in small quantities. Variations are produced for many customers and by providing to us the application specifications we might find an existing unit that fits your requirement. If we don't and the quantity is sufficient, we will design a “special unit” for the application.

Pictorial and dimensional data is subject to change without notice.

The information presented in this catalog is based on technical data and test results of nominal units. It is believed to be accurate and is offered as an aid in the selection of Gast products. It is the user's responsibility to determine suitability of the product for intended use and the user assumes all risk and liability whatsoever in connection therewith.

The chart below shows general performance ranges of our lubricated Air Motors. See if we have the right offering for your application.

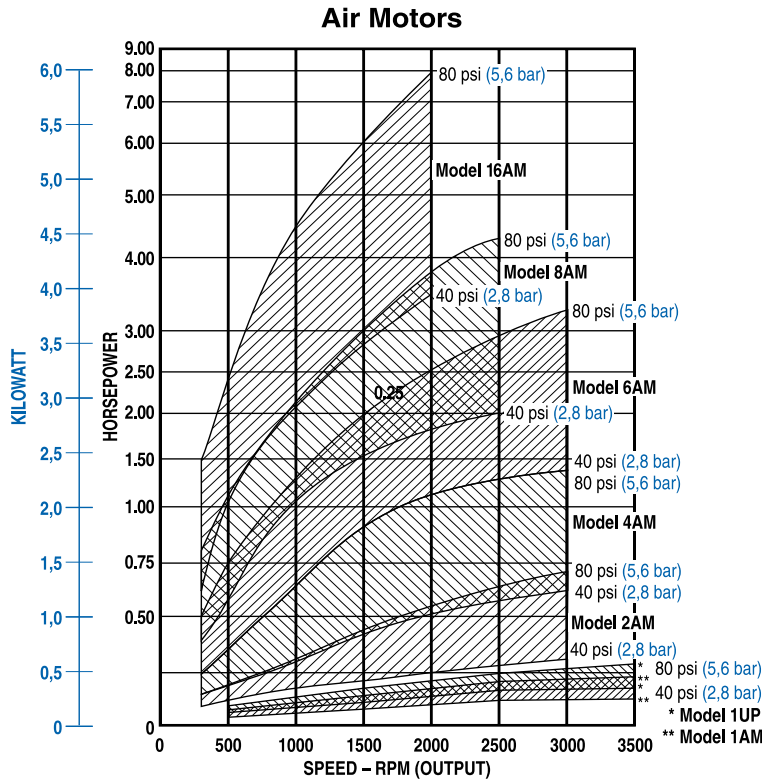

Use of Air Motors in Hazardous Atmospheres

Most of the Gast Air Motors and some of the Gast Gear Motors in this catalog meet the requirements of the EC directive 94/9EC (ATEX 100a). They may be used in zones 1 and 2 where explosive atmospheres of gas or dust are likely to occur. These are marked with II 2 G D c T4 in the catalogue and on the product. This indicates the air motor is Group II, Category 2, Gas and Dust Atmospheres, and a maximum surface temperature of 275 °F/135 °C. Check that the product driven by the air motor meets ATEX directive.

There are several points regarding the safety of air motors. Our air motors are not a source of electric sparks. However, it is possible that an article which is not part of the air motor (e.g., wrenches, hammers, etc.) could create a spark by sharply impacting a cast iron or aluminum case or the steel shaft of the air motor. [Note that electric motor enclosures for both class I and II hazardous locations can be made of "...iron, steel, copper, bronze, or aluminum..." (UL 674, Electric Motors and Generators - Hazardous Locations, June 23, 1989; paragraph 4.2, page 6)].

Gast Air Motors are designed to be operated by compressed air, the expansion of which creates a cooling effect. As a result, the outside surface temperature of the air motor will not reach ignition temperature and a maximum surface temperature of 275 °F/135 °C. Operation of the air motor with compressed air purges a flammable mixture from the inside of the air motor.

To prevent static electricity from being an ignition source electrically ground the metal air motor.

We do not guarantee the safety of any application, but to ensure the safe operation of an air motor in your application, always follow the product operation manual, follow ATEX 100a when operating in a hazardous atmosphere and consult with a qualified engineer.

Performance, Features and Typical Applications



Performance

Up to 9.5 HP (7,1 kW)
Variable speeds to 10,000 rpm
Gear motor maximum torque to 5200 lb. in. (587 Nm)



Features

Variable speed
Non-electrical sparking
Cool running
Compact and portable
Operate in all positions
Mounting flexibility



Typical Applications

Mixing equipment
Conveyor drives
Pump drives
Food packaging
Pharmaceutical packaging
Hoists and winches
Hose reels
Fiberglass choppers
Tension devices
Turntables
Tire/wheel balancers



Model

4AM-NRV-200SS Face Mount

(4 Vanes, Reversible) 11.5 lbs (5.2 kg)

4AM-NRV-201SS NEMA 56C

(4 Vanes, Reversible) 16.6 lbs (7.5 kg)

FEATURES

- Sanitary Design
- 304 stainless steel housing, rotor and output shaft
- Face or flange mounting
- Any plane operation
- Fully sealed
-  IP65

RECOMMENDED

- Filter AH100F
- Regulator AH101R
- Gauge AA807
- Lubricator AH102L
- Food Grade Oil AS117

Product Dimensions (inches, mm)

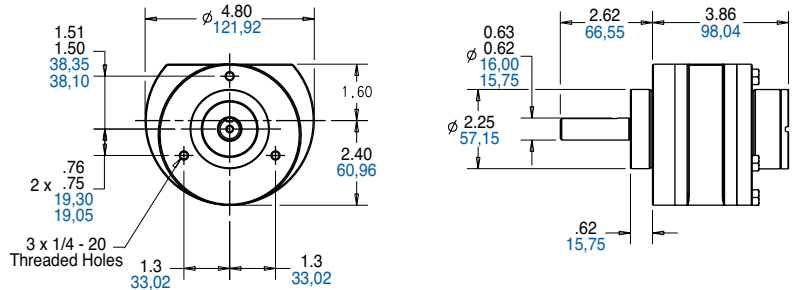

4AM-NRV-200SS

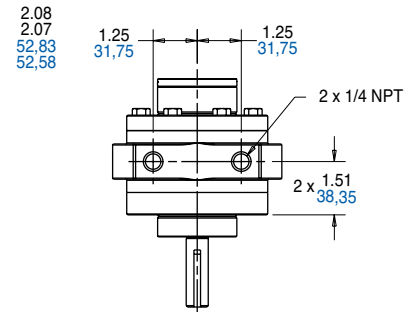

Product Dimensions (inches, mm)

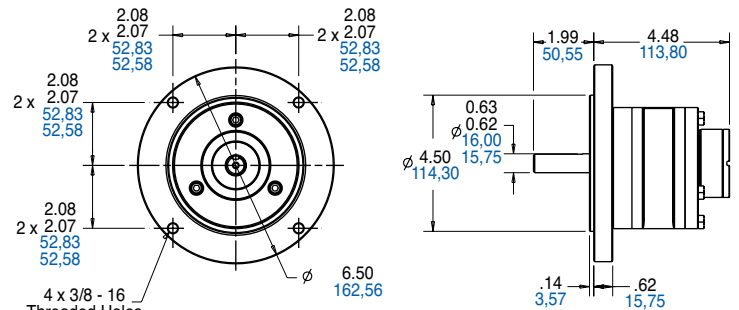

4AM-NRV-201SS

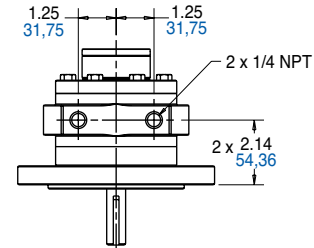

Output Power vs. Speed

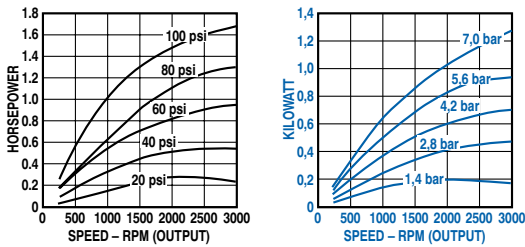

Torque vs. Speed

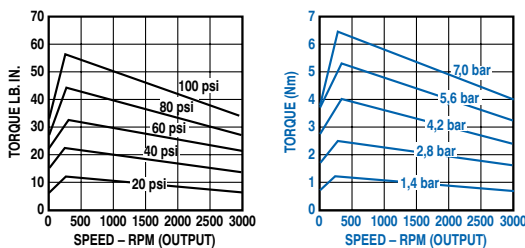

Air Consumption vs. Speed

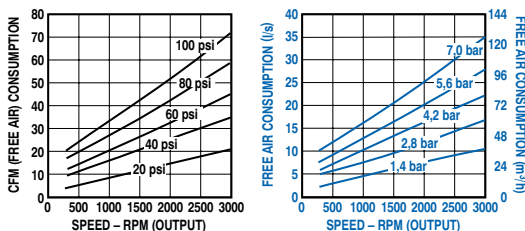

Model

6AM-NRV-200SS, Face Mount

(4 Vanes, Reversible) 17.0 lbs (7.7 kg)

6AM-NRV-201SS, NEMA 56C

(4 Vanes, Reversible) 22.1 lbs (1.0 kg)

FEATURES

- Sanitary Design
- 304 stainless steel housing, rotor and output shaft
- Face or flange mounting
- Any plane operation
- Fully sealed
-  2 GD c T4

RECOMMENDED

- Filter AH100F
- Regulator AH101R
- Gauge AA807
- Lubricator AH102L
- Food Grade Oil AS117

Product Dimensions (inches, mm)

6AM-NRV-200SS

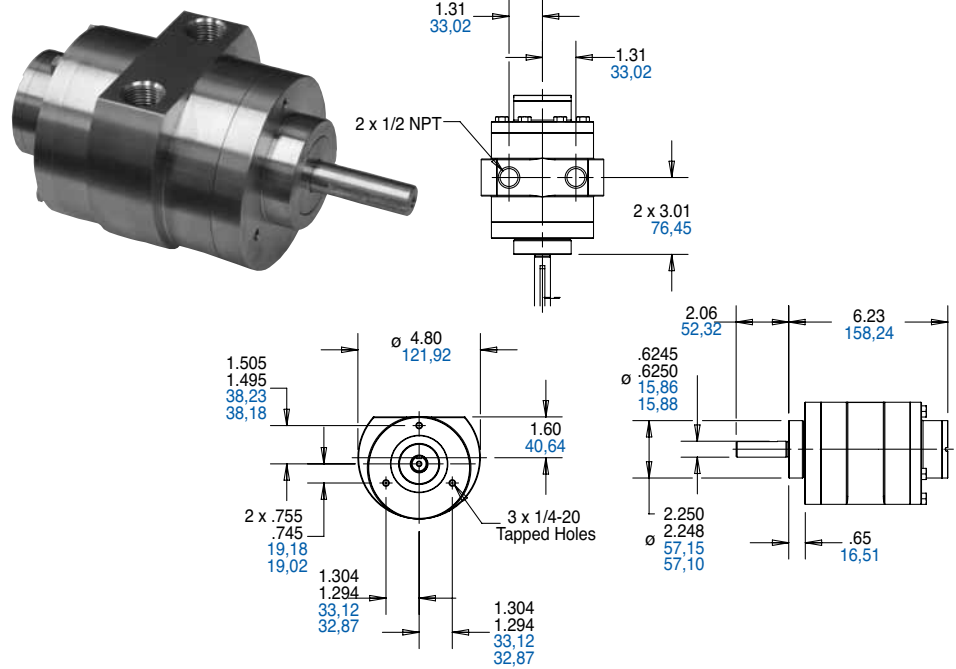

Output Power vs. Speed

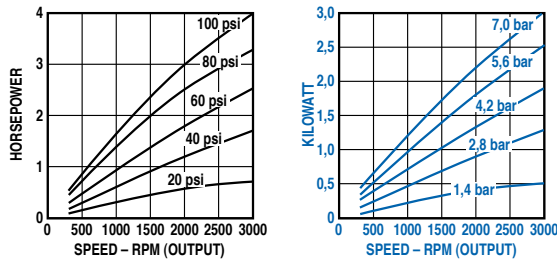

Torque vs. Speed

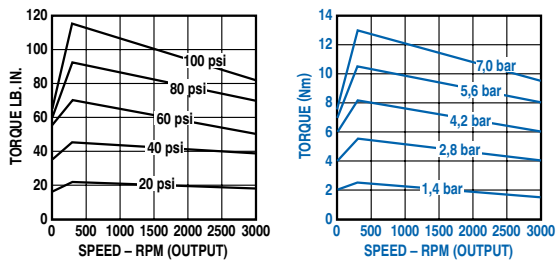

Air Consumption vs. Speed

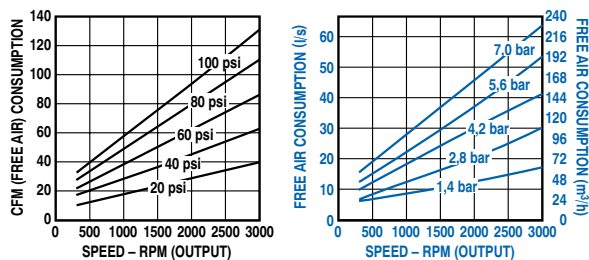

6AM-NRV-201SS

Product Dimensions (inches, mm)

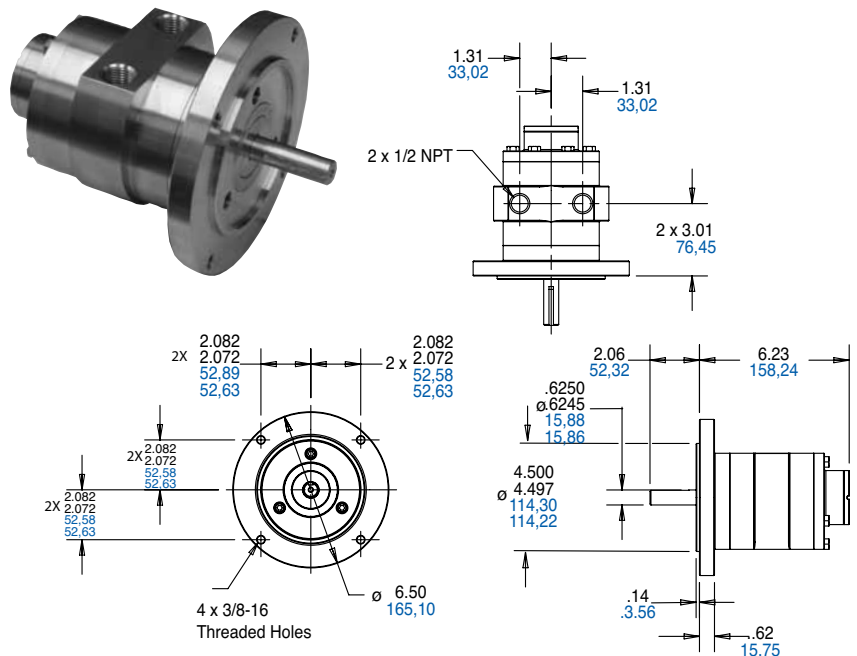

Model

1AM-NCC-12 (4 Vanes, CCW Rotation)

1AM-NCW-14 (4 Vanes, CW Rotation)

1AM-NRV-39A (4 Vanes, Reversible)

1AM-NRV-63A (8 Vanes, Reversible)

Net wt. 2 lbs (0,9 kg)

FEATURES

- Hub mounting
- Any plane operation
- Muffler AF350
-  II, 2 GD c T4

RECOMMENDED

- Filter AH100F
- Regulator AH101R
- Gauge AA806
- Lubricator AH102L
- Oil AD220 – 1 quart (.94 liters)
- Repair kit K200 (Single Rotation)
- Repair kit K201 (Reversible)
- Repair kit K278 (8 Vane, Reversible)

OPTIONAL

- Foot mounting (see page 38)



Product Dimensions (inches, mm)

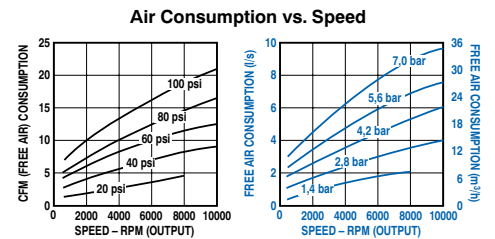
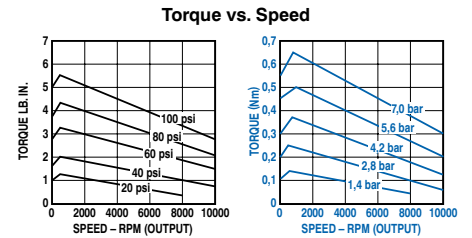
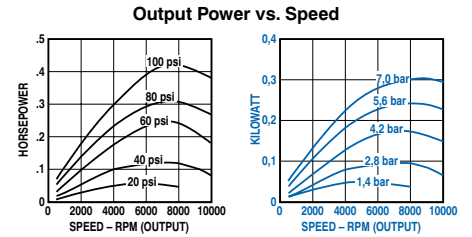
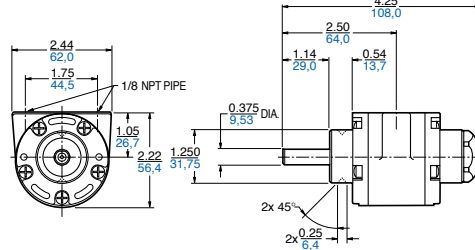

1UP-NCC-1A (4 Vanes, CCW Rotation)

1UP-NCW-2A (4 Vanes, CW Rotation)

1UP-NRV-3A (4 Vanes, Reversible)

1UP-NRV-10 (8 Vanes, Reversible)

Net wt. 3 lbs (1,4 kg)

FEATURES

- Hub mounting
- Any plane operation
- Muffler AF350
-  II, 2 GD c T4

RECOMMENDED

- Filter AH100F
- Regulator AH101R
- Gauge AA807
- Lubricator AH102L
- Oil AD220 – 1 quart (.94 liters)
- Repair kit K285 (Single Rotation)
- Repair kit K286 (Reversible)
- Repair kit K298 (8 Vane, Reversible)

OPTIONAL

- Foot mounting (see page 38)



Product Dimensions (inches, mm)

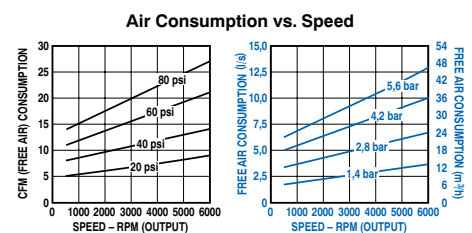
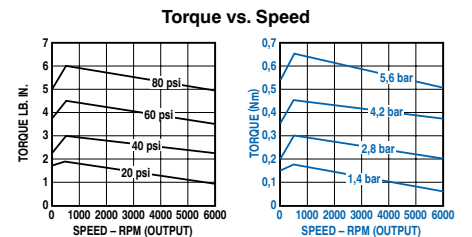
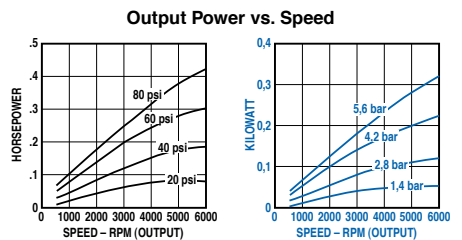
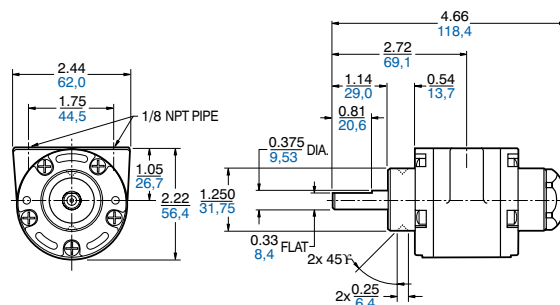

Model

2AM-FCC-1 (4 Vanes, CCW Rotation)

2AM-FCW-13 (4 Vanes, CW Rotation)

Net wt. 7 lbs (3,2 kg)

FEATURES

- Foot mounting
- Any plane operation
- Metal muffler AC980 adds 2" height when installed

-  II 2 GD c T4

RECOMMENDED

- Filter AH103F
- Regulator AH104R
- Gauge AA806
- Lubricator AH105L
- Oil AD220 – 1 quart (.94 litres)
- Repair kit K202 (Single Rotation)



Product Dimensions (inches, mm)

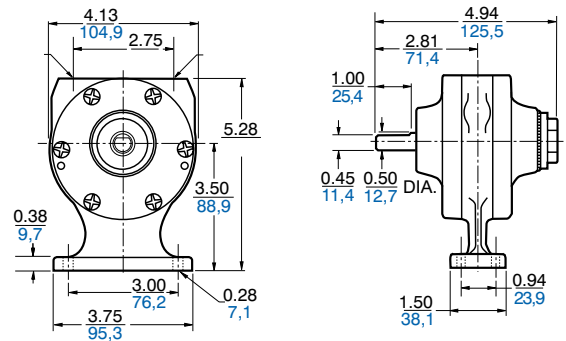

2AM-NCC-16 (4 Vanes, CCW Rotation)

2AM-NCW-7B (4 Vanes, CW Rotation)

2AM-NRV-89 (4 Vanes, Reversible)

Net wt. 6 lbs (2,7 kg)

FEATURES

- Hub mounting
- Any plane operation
- Metal muffler AC980 adds 2" height when installed

-  II 2 GD c T4

RECOMMENDED

- Filter AH103F
- Regulator AH104R
- Gauge AA806
- Lubricator AH105L
- Oil AD220 – 1 quart (.94 litres)
- Repair kit K202 (Single Rotation)
- Repair kit K509 (Reversible)



Product Dimensions (inches, mm)

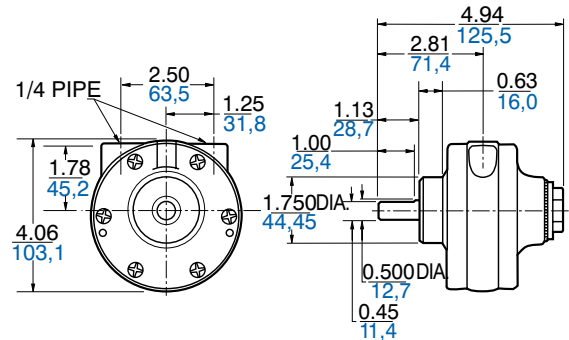

2AM-NCC-43A (4 Vanes, CCW Rotation)

2AM-NRV-90 (4 Vanes, Reversible)

Net wt. 15 lbs (6,8 kg)

FEATURES

- NEMA 56C mounting
- Any plane operation
- Metal muffler AC980 adds 2" height when installed

-  II 2 GD c T4

RECOMMENDED

- Filter AH103F
- Regulator AH104R
- Gauge AA806
- Lubricator AH105L
- Oil AD220 – 1 quart (.94 litres)
- Repair kit K203A (Single Rotation)
- Repair kit K510 (Reversible)



Product Dimensions (inches, mm)

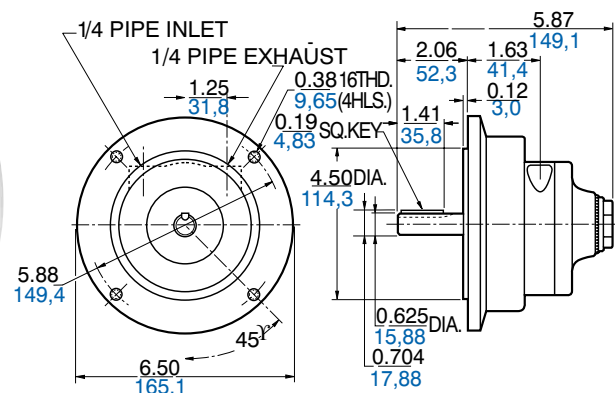

Model

2AM-ACC-88

(4 Vanes, CCW Rotation)
Flange Mount

2AM-ACC-91

(4 Vanes, CCW Rotation)
Face Mount

2AM-ARV-92

(4 Vanes, Reversible)
Flange Mount

2AM-ARV-93

(4 Vanes, Reversible)
Face Mount

FEATURES

- IEC #72 mounting frame size:
D71 (2AM-ACC-88, 2AM-ARV-92)
D71C (2AM-ACC-91, 2AM-ARV-93)
- Any plane operation
- Metal muffler AC980 adds 2" height when installed
-  II 2 GD c T4

RECOMMENDED

- Repair kit K203A (Single Rotation)
- Repair kit K510 (Reversible)



Product Dimensions (inches, mm)

Models 2AM-ACC-88/2AM-ARV-92

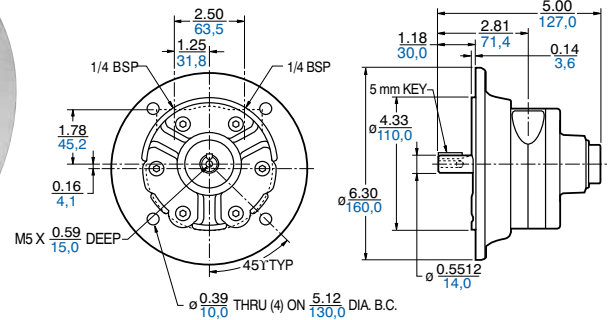

Models 2AM-ACC-91/2AM-ARV-93

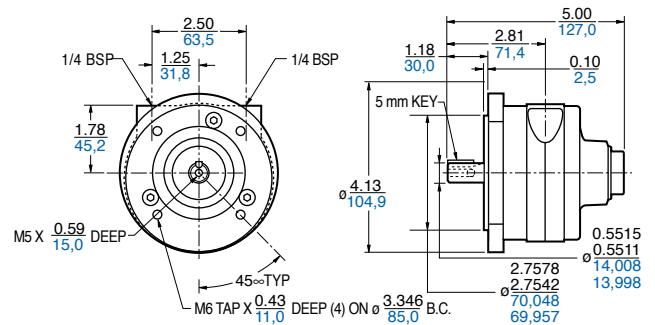

Delivers up to 0,56 kW ($\frac{3}{4}$ HP). Speeds may be varied from 300 to 3,000 rpm. Max. recommended operating pressure 7 bar (100 psi).

Output Power vs. Speed

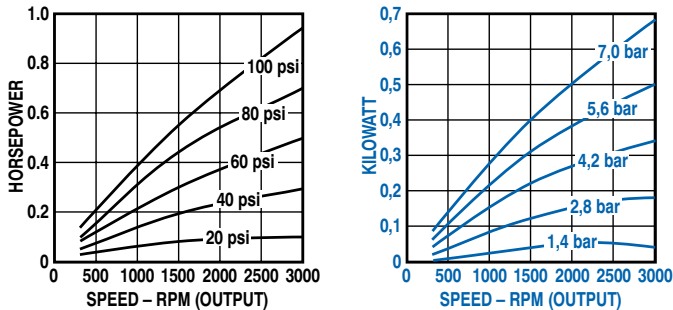

Air Consumption vs. Speed

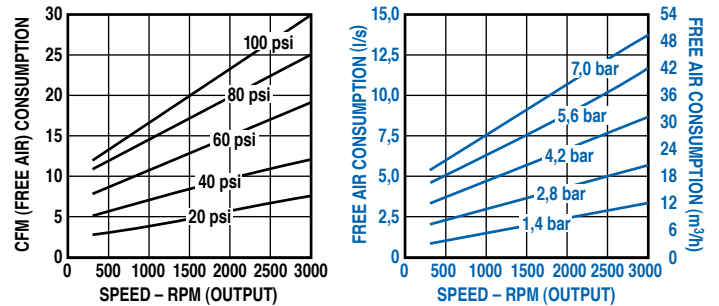

Torque vs. Speed

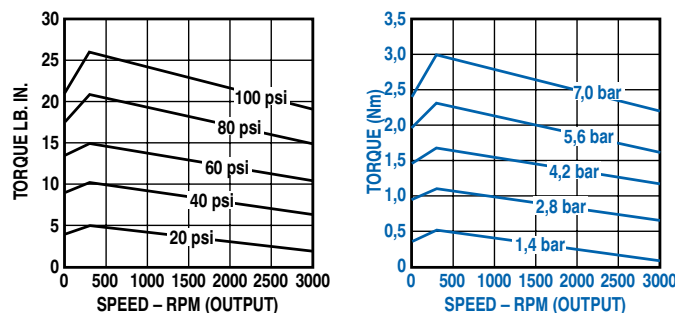

MODEL

4AM-FRV-24 (4 Vanes, Dual Shaft)

4AM-FRV-13C (4 Vanes, Reversible)

4AM-FRV-63A (8 Vanes, Reversible)

Net wt. 9 lbs (4,1 kg)

FEATURES

- Foot mounting
- Any plane operation
- Single or dual shaft
- Metal muffler AC980 adds 2" height when installed

-  II 2 GD c T4

RECOMMENDED

- Filter AH103F
- Regulator AH104R
- Gauge AA806
- Lubricator AH105L
- Oil AD220 – 1 quart (.94 litres)
- Repair kit K205 (4 Vane, Reversible)
- Repair kit K279 (8 Vane, Reversible)



Product Dimensions (inches, mm)

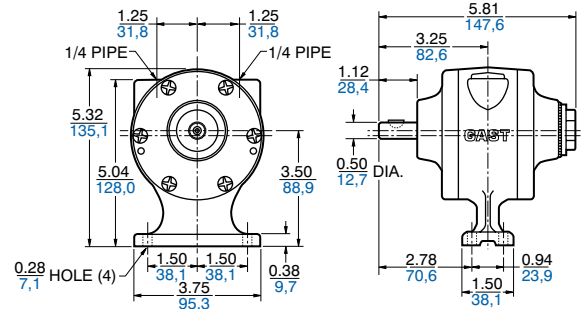

4AM-NRV-22B (4 Vanes, Reversible)

4AM-NRV-54A (8 Vanes, Reversible)

Net wt. 9 lbs (4,1 kg)

FEATURES

- Face mounting
- Any plane operation
- Metal muffler AC980 adds 2" height when installed

-  II 2 GD c T4

RECOMMENDED

- Filter AH103F
- Regulator AH104R
- Gauge AA806
- Lubricator AH105L
- Oil AD220 – 1 quart (.94 litres)
- Repair kit K205 (4 Vane, Reversible)
- Repair kit K279 (8 Vane, Reversible)



Product Dimensions (inches, mm)

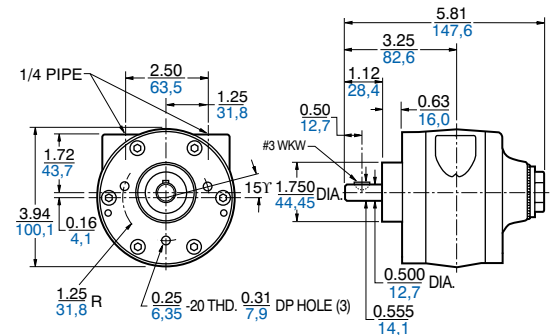

4AM-NRV-50C (4 Vanes, Reversible)

4AM-NRV-70C (8 Vanes, Reversible)

Net wt. 12 lbs (5,4 kg)

FEATURES

- NEMA 56C mounting
- Any plane operation
- Metal muffler AC980 adds 2" height when installed

-  II, 2 GD c T4

RECOMMENDED

- Filter AH103F
- Regulator AH104R
- Gauge AA806
- Lubricator AH105L
- Oil AD220 – 1 quart (.94 litres)
- Repair kit K206A (4 Vane)
- Repair kit K280A (8 Vane)



Product Dimensions (inches, mm)

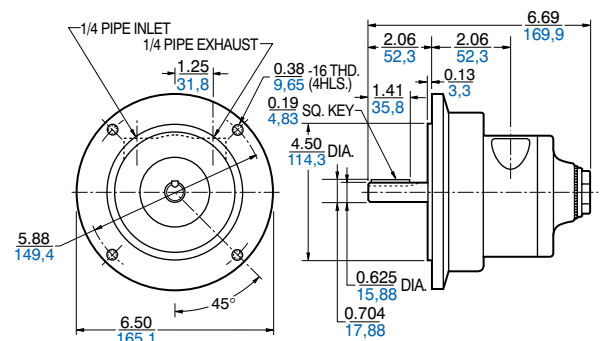

Model

4AM-ARV-119 (4 Vanes, Reversible)

4AM-ARV-120 (8 VANES, REVERSIBLE)

Net wt. 9 lbs (4,1 kg)

FEATURES

- IEC #72 mounting frame size D71
- Any plane operation
- Metal muffler AC980 adds 2" height when installed (Includes 3/8 BSP adaptor with air motor)

-  II 2 GD c T4

RECOMMENDED

- Repair kit K206C (4AM-ARV-119)
- Repair kit K208B (4AM-ARV-120)

Note: Performance data represents a 4-vane model with no exhaust restriction.



Product Dimensions (inches, mm)

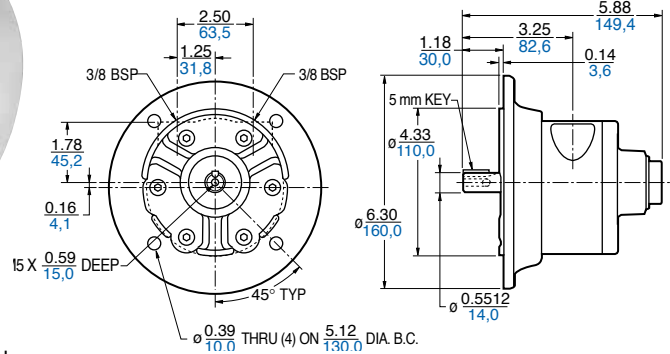

Delivers up to 1,5 kW (2 HP).
Speeds may be varied from 300 to 3,000 rpm. Max. recommended operating pressure 7 bar (100 psi).

Output Power vs. Speed

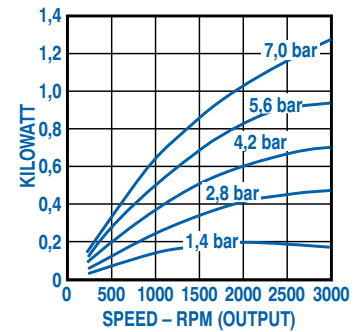
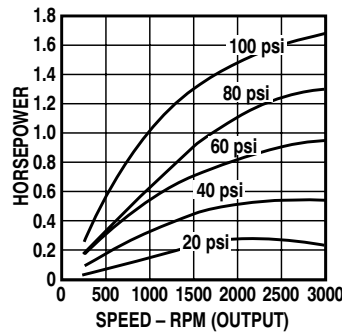

Torque vs. Speed

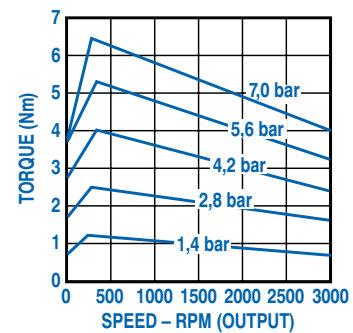
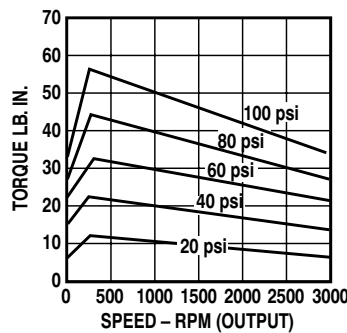

Air Consumption vs. Speed

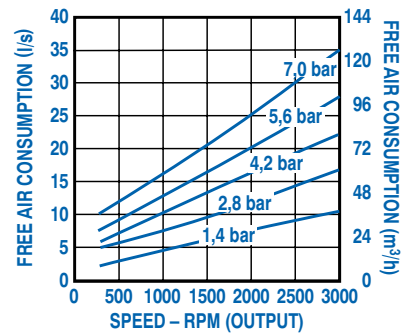
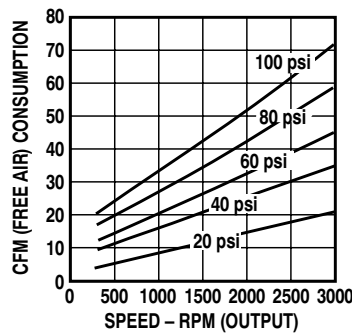

Model

6AM-FRV-5A (4 Vanes, Reversible)

6AM-FRV-23A (8 Vanes, Reversible)

Net wt. 21 lbs (9,5 kg)

FEATURES

- Foot mounting
- Any plane operation
- Metal muffler AC990 adds 2" height when installed

•  II 2 GD c T4

RECOMMENDED

- Filter AH106F
- Regulator AH107R
- Gauge AA806
- Lubricator AH108L
- Oil AD220 – 1 quart (.94 litres)
- Repair kit K208 (4 Vane)
- Repair kit K281 (8 Vane)



Product Dimensions (inches, mm)

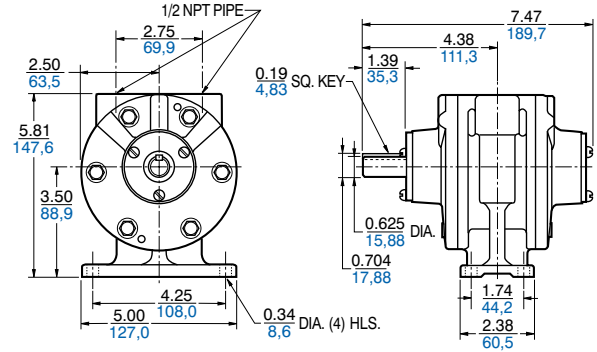

6AM-NRV-7A (4 Vanes, Reversible)

Net wt. 18 lbs (8,1 kg)

FEATURES

- Face mounting
- Any plane operation
- Muffler AC990 adds 2" height when installed

•  II 2 GD c T4

RECOMMENDED

- Filter AH106F
- Regulator AH107R
- Gauge AA806
- Lubricator AH108L
- Oil AD220 – 1 quart (.94 litres)
- Repair kit K208



Product Dimensions (inches, mm)

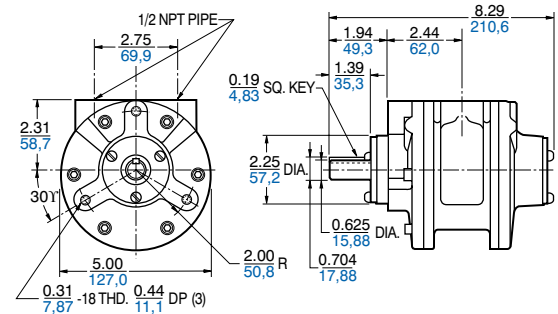

6AM-NRV-11A (4 Vanes, Reversible)

6AM-NRV-22A (8 Vanes, Reversible)

Net wt. 24 lbs (10,8 kg)

FEATURES

- NEMA 56C mounting
- Any plane operation
- Muffler AC990 adds 2" height when installed

•  II 2 GD c T4

RECOMMENDED

- Filter AH106F
- Regulator AH107R
- Gauge AA806
- Lubricator AH108L
- Oil AD220 – 1 quart (.94 litres)
- Repair kit K208 (4 Vane)
- Repair kit K281 (8 Vane)



Product Dimensions (inches, mm)

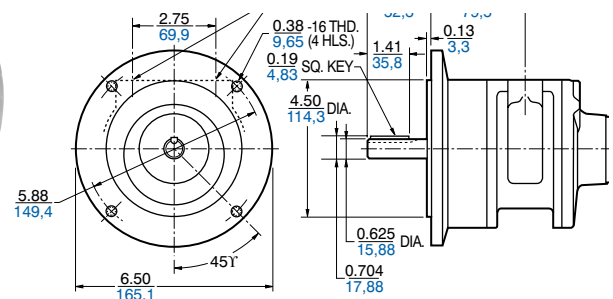

Model

8AM-FRV-2B (4 Vanes, Reversible)

8AM-FRV-30A (8 Vanes, Reversible)

Net wt. 27 lbs (12,2 kg)

FEATURES

- Foot mounting
- Any plane operation
- Metal muffler AC990 adds 2" height when installed

•  II 2 GD c T4

RECOMMENDED

- Filter AH106F
- Regulator AH107R
- Gauge AA806
- Lubricator AH108L
- Muffler AG600 – above 1,000 rpm
- Oil AD220 – 1 quart (.94 litres)
- Repair kit K210 (4 Vane)
- Repair kit K283 (8 Vane)



Product Dimensions (inches, mm)

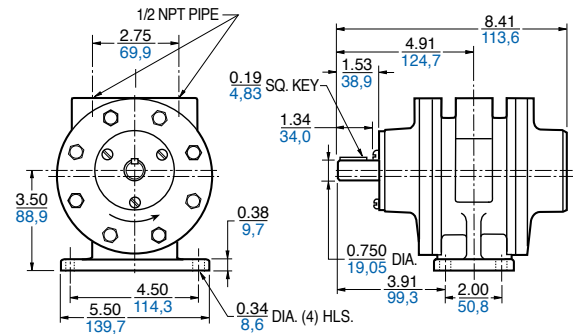

8AM-NRV-5B (4 Vanes, Reversible)

8AM-NRV-42A (8 Vanes, Reversible)

Net wt. 28 lbs (12,6 kg)

FEATURES

- Face mounting
- Any plane operation
- Metal muffler AC990 adds 2" height when installed

•  II 2 GD c T4

RECOMMENDED

- Filter AH106F
- Regulator AH107R
- Gauge AA806
- Lubricator AH108L
- Muffler AG600 – above 1,000 rpm
- Oil AD220 – 1 quart (.94 litres)
- Repair kit K210 (4 Vane)
- Repair kit K283 (8 Vane)



Product Dimensions (inches, mm)

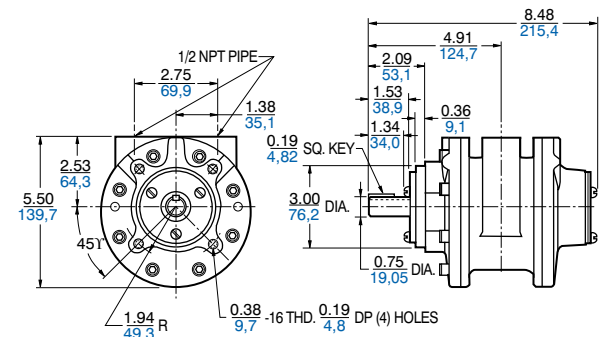

8AM-NRV-28A (4 Vanes, Reversible)

8AM-NRV-32A (8 Vanes, Reversible)

Net wt. 28 lbs (12,6 kg)

FEATURES

- NEMA 145TC mounting
- Any plane operation
- Metal muffler AC990 adds 2" height when installed

•  II 2 GD c T4

RECOMMENDED

- Filter AH106F
- Regulator AH107R
- Gauge AA806
- Lubricator AH108L
- Muffler AG600 – above 1,000 rpm
- Oil AD220 – 1 quart (.94 litres)
- Repair kit K211 (4 Vane)
- Repair kit K282 (8 Vane)



Product Dimensions (inches, mm)

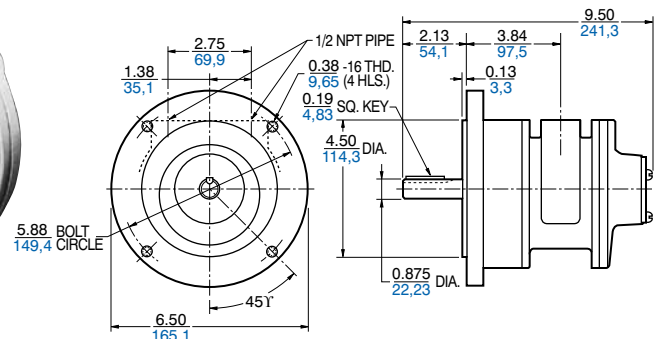

Model

8AM-ARV-70

(4 Vanes, Reversible)

Net wt. 28 lbs (12,6 kg)

FEATURES

- IEC #72 mounting frame size D90
- Any plane operation
- Metal muffler AC990 adds 2" height when installed

-  II 2 GD c T4

RECOMMENDED

- Repair kit K282A



Product Dimensions (inches, mm)

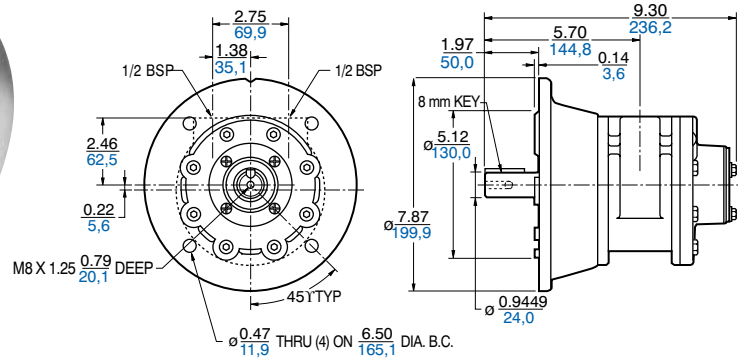

8AM-ARV-71

(8 Vanes, Reversible)

Net wt. 28 lbs (12,6 kg)

FEATURES

- IEC #72 mounting frame size D90
- Any plane operation
- Metal muffler AC990 adds 2" height when installed

-  II 2 GD c T4

RECOMMENDED

- Repair kit K282B

Delivers up to 3,7 kW (5 HP). Speeds may be varied from 300 to 2,500 rpm. Max. recommended operating pressure 7 bar (100 psi).

Note: Performance data represents a 4-vane model with no exhaust restriction.

Output Power vs. Speed

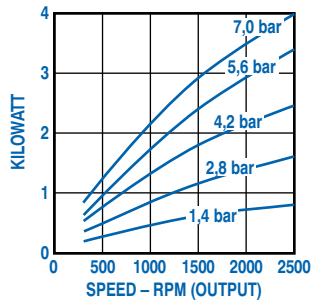
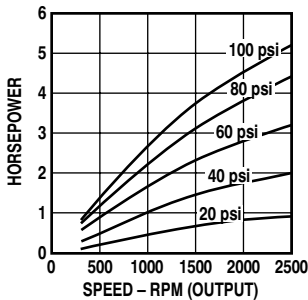

Torque vs. Speed

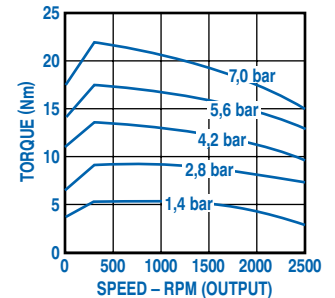
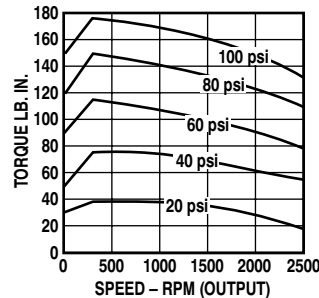

Air Consumption vs. Speed

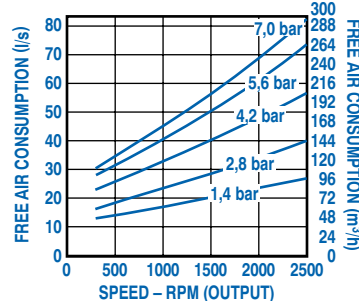
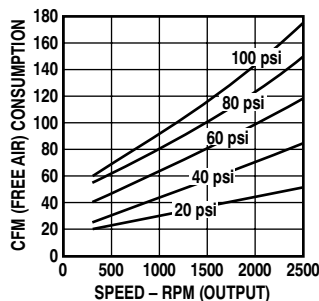

Model

16AM-FCC-1

(6 Vanes, CCW Rotation)

16AM-FRV-2

(6 Vanes, Reversible)

16AM-FCW-28

(6 Vanes, CW Rotation)

Net wt. 72 lbs (32,4 kg) and 73 lbs (32,9 kg) respectively.

FEATURES

- Foot and face mounting
- Any plane operation

•  II 2 GD c T4

RECOMMENDED

- Filter AH109F
- Regulator AH110R
- Gauge AA806
- Lubricator AH111L
- Muffler AG601
- Oil AD220 – 1 quart (.94 litres)
- Repair kit K212 (Single Rotation)
- Repair kit K213 (Reversible)



Product Dimensions (inches, mm)

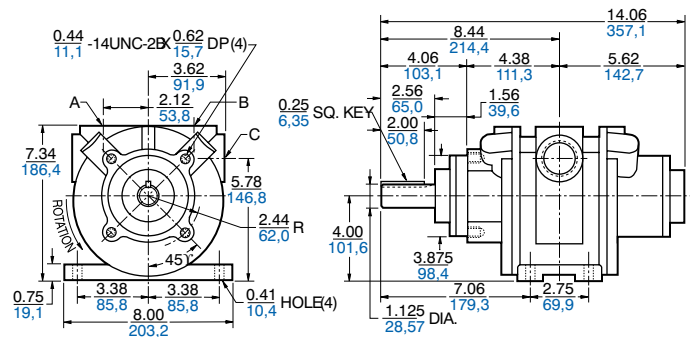

Rotation	A	B	C
Single direction	1 PIPE	NONE	1 1/4 PIPE
Reversible	1 1/4 PIPE	1 1/4 PIPE	NONE

16AM-FRV-13

(6 Vanes, Reversible)

Net wt. 80 lbs (36,0 kg)

FEATURES

- NEMA 143 and 145TC mounting
- Any plane operation

•  II 2 GD c T4

RECOMMENDED

- Filter AH109F
- Regulator AH110R
- Gauge AA806
- Lubricator AH111L
- Muffler AG601
- Oil AD220 – 1 quart (.94 litres)
- Repair kit K213



Product Dimensions (inches, mm)

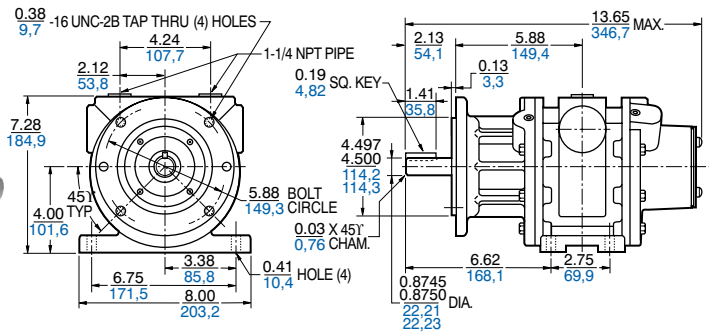

Output Power vs. Speed

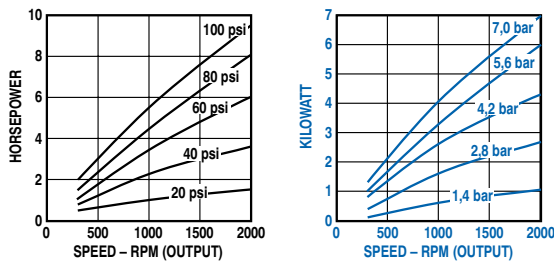

Torque vs. Speed

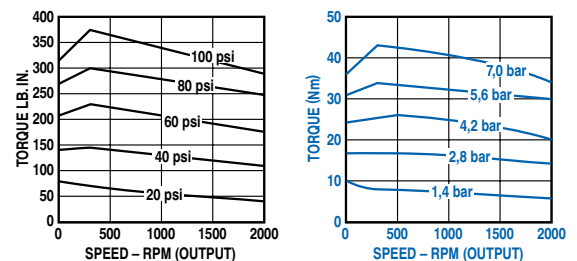

Air Consumption vs. Speed

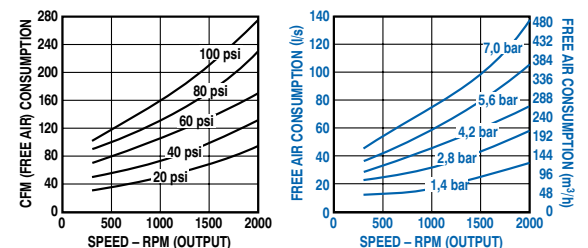

Non-lubricated Air Motors

The NL Series - an alternative to our traditional lubricated styles because no lubricator is necessary

For those air motor applications where contaminated exhaust cannot be tolerated in the workplace, Gast's non-lubricated Air Motors, the NL series, provide the solution.



- **Rugged and Reliable**

Like our traditional lubricated air motors, the NL series will provide thousands of hours of service-free life. Vanes are just as easy and inexpensive to replace.

- **Performance Flexibility**

Gast's non-lubricated air motors are designed so that compressor carry-over will not gum up the vanes. In fact, while no lubrication whatsoever is required to operate the motors, small amounts of oil and water will actually improve the performance.

- **Corrosion Resistant**

Because the body, rotor, and end plates are specially treated, these air motors can tolerate unfavorable moisture-laden conditions.

- **No Oil Expenses**

If you are using several quarts of oil throughout the year, you'll eliminate that expense with non-lubricated air motors.

- **No Periodic Inspection**

With no in-line lubrication system to replenish, the need for time consuming maintenance checks is eliminated.

Gast's non-lubricated Air Motors provide the advantages and benefits of traditional lubricated air motors which include:

- Variable speed
- Non-electrical sparking
- Cool running
- Minimal maintenance
- No-shock starts
- Any plane operation

Model

NL22-NCC-1

(4 Vanes, CCW Rotation)

NL22-NCW-2

(4 Vanes, CW Rotation)

NL22-FCC-3

(4 Vanes, CCW Rotation)

NL22-FCW-4

(4 Vanes, CW Rotation)

Net wt. 3 lbs (1,4 kg)

FEATURES

- Hub or foot mounting
- Treated body, rotor, and end plates for corrosion resistance
- No lubrication necessary - no contaminated air in the work area
- Any plane operation
- Muffler AF350
-  II 2 GD c T4

RECOMMENDED

- Filter AH100F
- Regulator AH101R
- Gauge AA807
- Repair kit K285A



Hub mounting model shown with muffler attached

Hub mounting (NL22-NCC-1, NL22-NCW-2)

Product Dimensions (inches, mm)

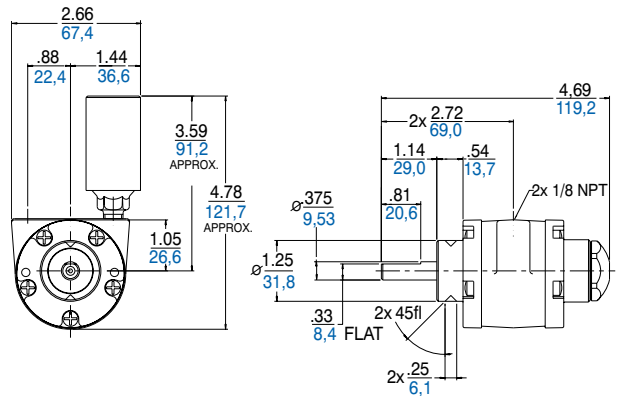

Foot mounting (NL22-FCC-3, NL22-FCW-4)

Product Dimensions (inches, mm)

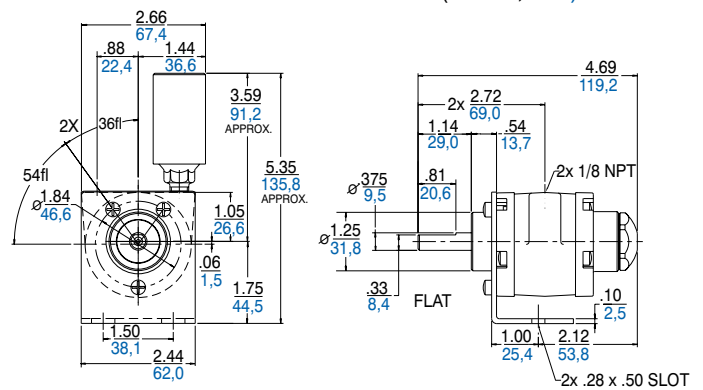

Output Power vs. Speed

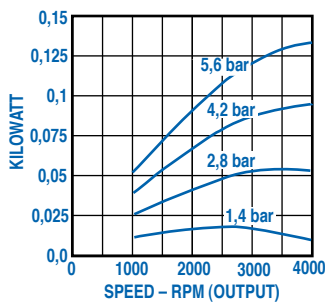
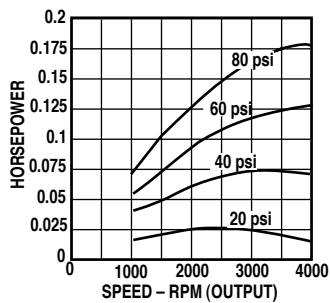

Torque vs. Speed

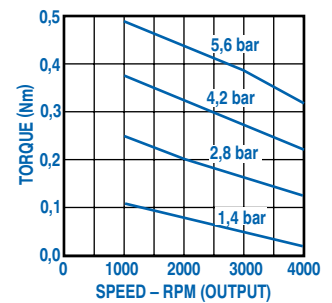
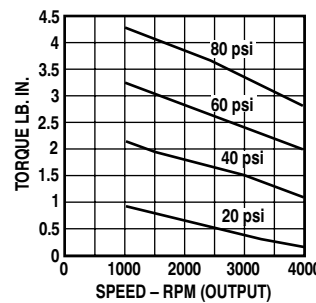

Air Consumption vs. Speed

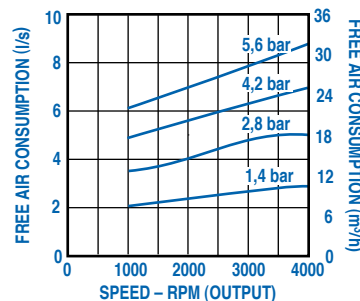
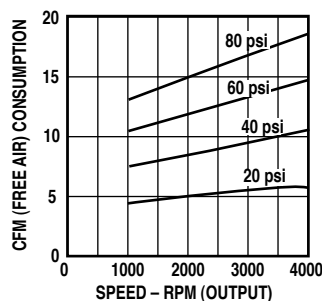

Model

NL42-NCC-1

(4 Vanes, CCW Rotation)

NL42-NCW-2

(4 Vanes, CW Rotation)

Net wt. 18 lbs (8,2 kg)

NL42-NCC-5

(4 Vanes, CCW Rotation)

NL42-NCW-6

(4 Vanes, CW Rotation)

NL42-NCC-7

(4 Vanes, CCW Rotation)

Net wt. 21 lbs (9,5 kg)



Hub mounting (NL42-NCC-1, NL42-NCW-2)

Product Dimensions (inches, mm)

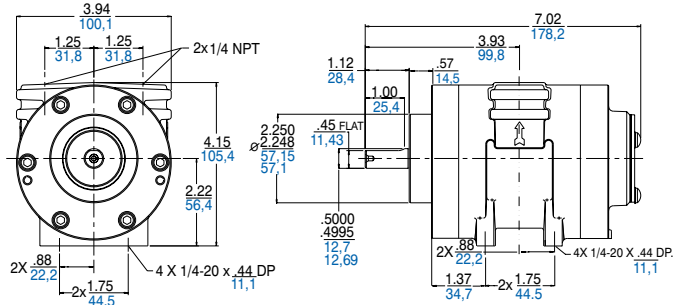

NEMA 56C, U.S. - (NL42-NCC-5, NL42-NCW-6)
D71 Flange, Metric - (NL42-NCC-7)

Product Dimensions (inches, mm)

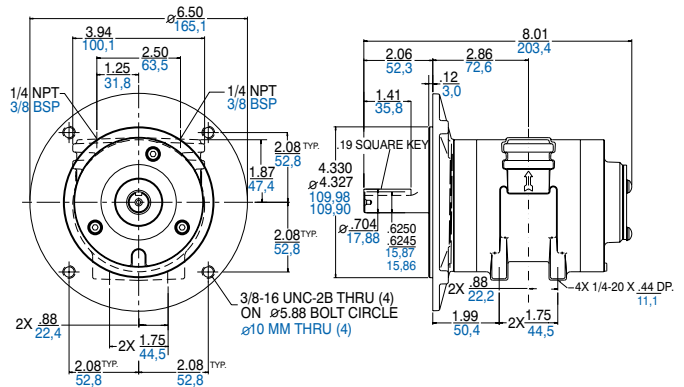

FEATURES

- Hub or foot mounting
- Treated body, rotor, and end plates for corrosion resistance
- No lubrication necessary - no contaminated air in the work area
- Any plane operation
- Metal muffler AC980 adds 2" height when installed
- II 2 GD c T4

RECOMMENDED

- Filter AH103F
- Regulator AH104R
- Gauge AA806
- Repair kit K580

OPTIONAL

- Foot kit AL414 - each of these models can be turned into foot mounted styles with the installation of optional foot kit AL414, which will add approx. 2" height to the air motor.
- Hub mounting model shown with optional foot assembly kit which can be purchased separately.
- Flange style is shown in schematic

Output Power vs. Speed

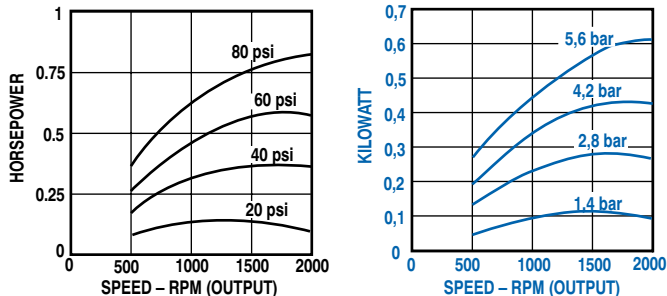

Torque vs. Speed

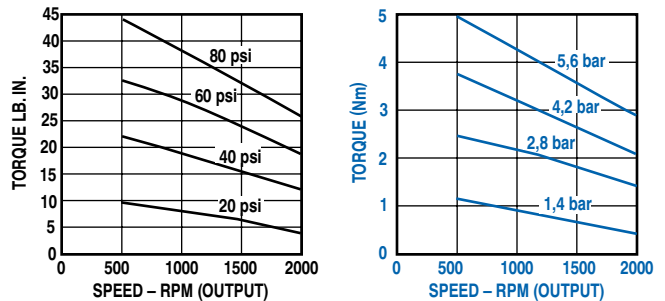

Air Consumption vs. Speed

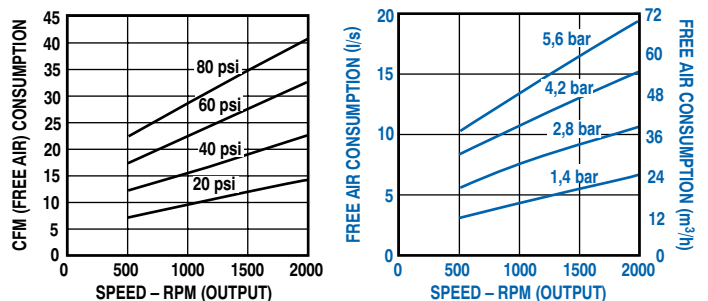

Model

NL52-NCC-1

(4 Vanes, CCW Rotation)

NL52-NCW-2

(4 Vanes, CW Rotation)

Net wt. 13 lbs (6 kg)

NL52-NCC-3

(4 Vanes, CCW Rotation)

NL52-NCW-4

(4 Vanes, CW Rotation)

Net wt. 14.5 lbs (6,6 kg)

FEATURES

- Hub, NEMA 56C, 6AM, or foot mounting
- Treated body, rotor, and end plates for corrosion resistance
- No lubrication necessary - no contaminated air in the work area
- Any plane operation
- Metal muffler AC990 adds 2" height when installed
-  II 2 GD c T4



- Hub mounting model shown with optional foot assembly kit which can be purchased separately.

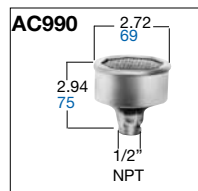

RECOMMENDED

- Filter AH106F
- Regulator AH107R
- Gauge AA806
- Repair kit K833

OPTIONAL

- Foot kit AL414 - each of these models can be turned into foot mounted styles with the installation of optional foot kit AL414, which will add approx. 2" height to the air motor

Air Consumption vs. Speed

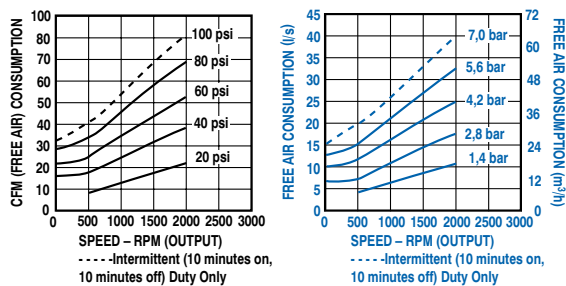

Torque vs. Speed

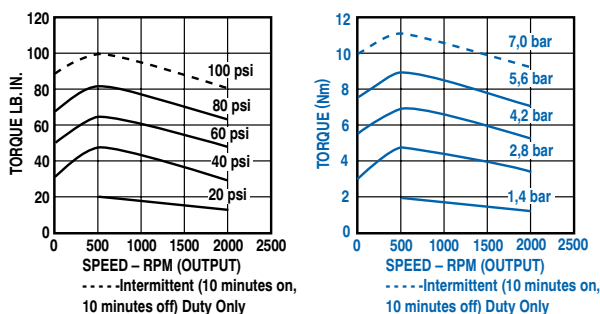

Product Dimensions (inches, mm)

Hub mounting (NL52-NCC-1, NL52-NCW-2)

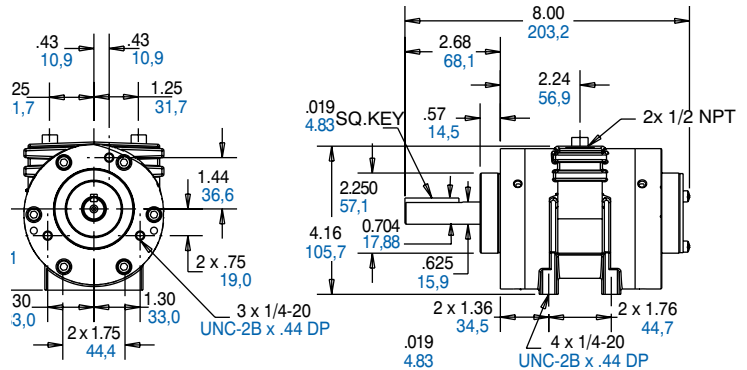

NEMA 56C, U.S. (NL52-NCC-3, NL52-NCW-4)

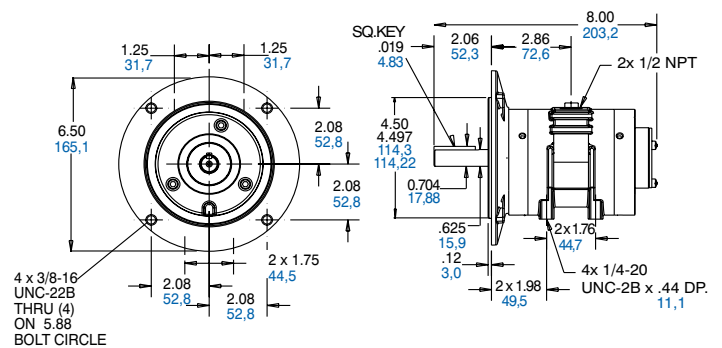

6AM Hub Mounting (NL52-NCC-5, NL52-NCW-6) Mounting identical to 6AM-NRV-7A for field replacement

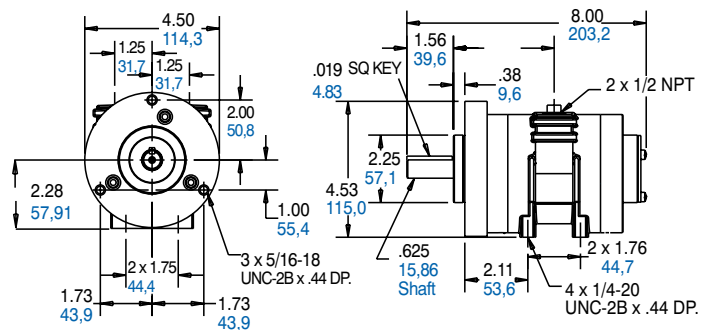

Output Power vs. Speed

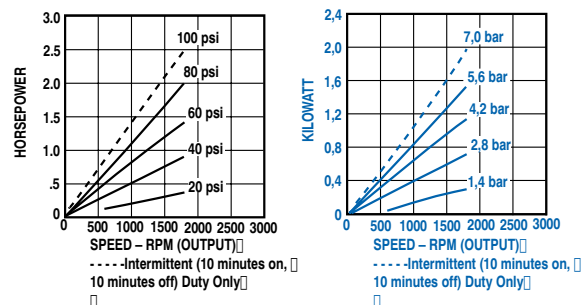

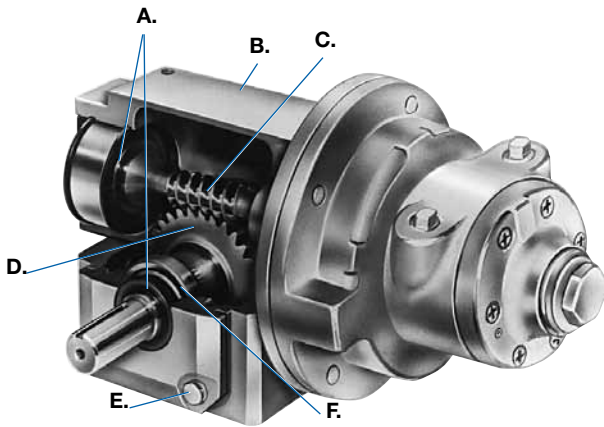

Pictured: typical right angle, worm gear reducer.

A. Bearings

Ball bearings used on input shaft; tapered roller bearings used on output shaft.

B. Case

Fine close-grain cast iron; crankcase sealed; duplex-milled for parallelism of mounting surfaces.

C. Worm

8620 alloy steel thread rolled to give uninterrupted grain pattern; carburized and hardened after rolling; high-burnish contact surface from rolling reduces friction coefficient for less heat generation, lower power losses. In large sizes, worms are cut, hardened, and ground to a good micro-finish, providing the ultimate in efficiency and torque capacity.

D. Worm Gear

Forged bronze; geometry and high helix angle give maximum beam strength, high efficiency.

E. Cap Screw

High-strength fasteners with corresponding torque specifications prevent loosening or breaking.

F. Seals

Double-dipped and spring-loaded for leak proofing; tested to ensure compatibility with lubricant.

Get the right gear motor with all the right options

More reasons why you should switch from electricity to air.

If you compare Gast Air-Powered Gear Motors with any electric-powered gear motor, there's really no comparison. Here's why:

- **More Horsepower**

Size for size, weight for weight, you can't beat a Gast Gear Motor. A typical rotary vane air motor – the type used in gear motors – developing 2½ HP (1,9 kW) at 1800 rpm and 90 psi (6,2 bar), weighs just 17 pounds (7,7 kg). A comparable electric motor may be two or three times heavier.

- **More Speed Control**

You can't get more precise turning power than with a Gast Gear Motor. In applications where you need variable speed – like bolt tensioning equipment or rock drilling rigs – one-speed electric motors just won't fit the bill. Precise lifting, lowering, or turning is simple with Gast Gear Motors.

- **More Flexibility**

More than most standard electric-powered gear reducers can provide. Gast Gear Motors give you infinitely variable turning power from 73 to 5200 lb. in. (8 to 587 Nm) of torque. And Gast Gear Motors are instantly reversible through easy valving in the air line.

- **More Configurations**

That makes it easier for our product to work in your product. Our Gear Motors are available in four mounting configurations.

- **More Life**

Unlike electric-powered gear motors, there's no chance of burnout with a Gast Gear Motor. They can be stalled indefinitely with no heat buildup. They're non-electrical sparking too, which makes them ideal for use in potentially explosive environments – places where you couldn't even consider electricity.

⚠ WARNING: Gast Air Powered Gear Motors are not self-locking. In applications where a break is required for safety in case of air pressure failure, call 800-952-4278 for your nearest distributor.

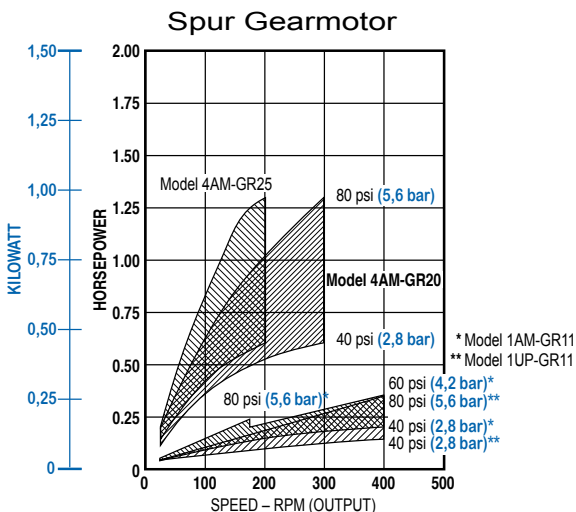

Model

2AM-43A-AF20

(4 Vanes, Reversible)

Net wt. 24 lbs (10,9 kg)

FEATURES

- 20:1 gear reducer
- Flange mounting
- Base-mounted
- Metal muffler AC980 provided not shown
AC980 adds 2" height when installed

RECOMMENDED

- Filter AH103F
- Regulator AH104R
- Gauge AA806
- Lubricator AH105L
- Oil AD220 – 1 quart (.94 litres)
- Repair kit K509

Max. allowable overhung load on the output shaft is 240 lbs
Max allowable thrust load on the output shaft is 300 lbs



Product Dimensions (inches, mm)

Counter-clockwise output shaft rotation

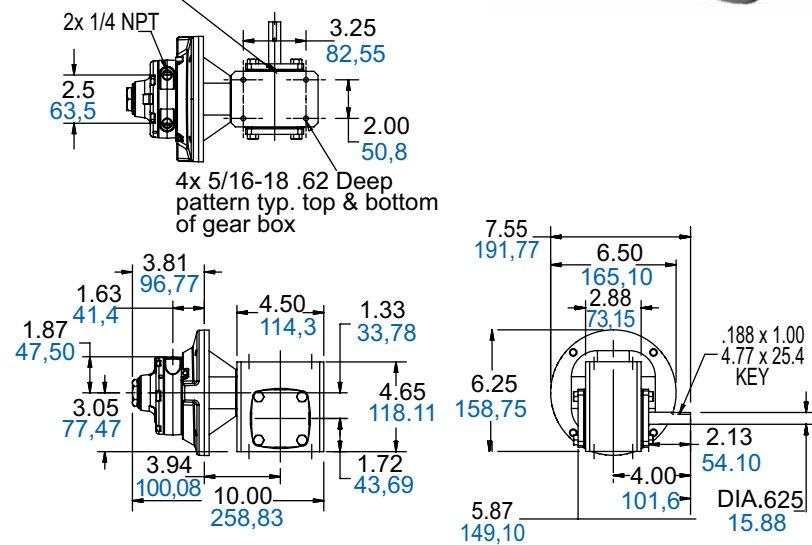

Air Consumption vs. Speed

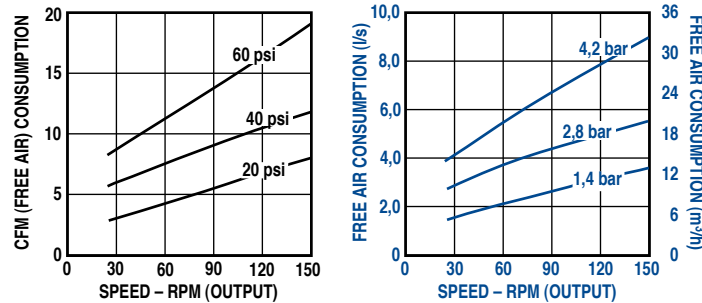

Torque vs. Speed

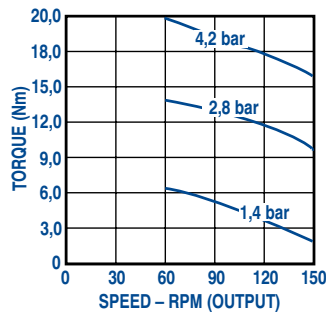
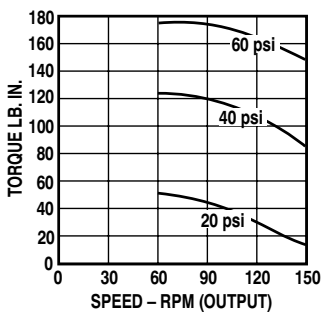

Output Power vs. Speed

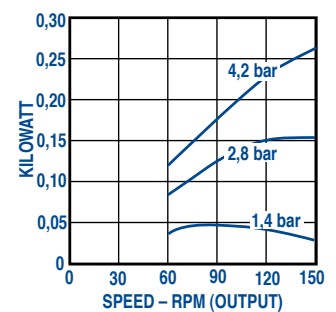
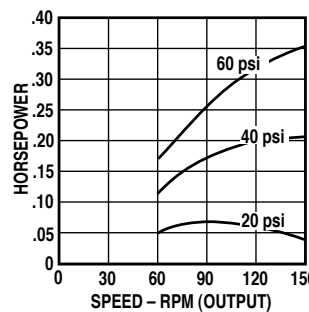

Model

Max. allowable overhung load on the output shaft is 600 lbs
 Max. allowable thrust load on the output shaft is of 500 lbs

2AM-43A-BF20

(4 Vanes, Reversible)

Net wt. 33.55 lbs (15,2 kg)

FEATURES

- 20:1 gear reducer
- FLANK mounting
- Mount on any plane operation
- Metal muffler AC980 provided not shown
 AC980 adds 2" height when installed

RECOMMENDED

- Filter AH103F
- Regulator AH104R
- Gauge AA806
- Lubricator AH105L
- Oil AD220 – 1 quart (.94 litres)
- Repair kit K509

Product Dimensions (inches, mm)

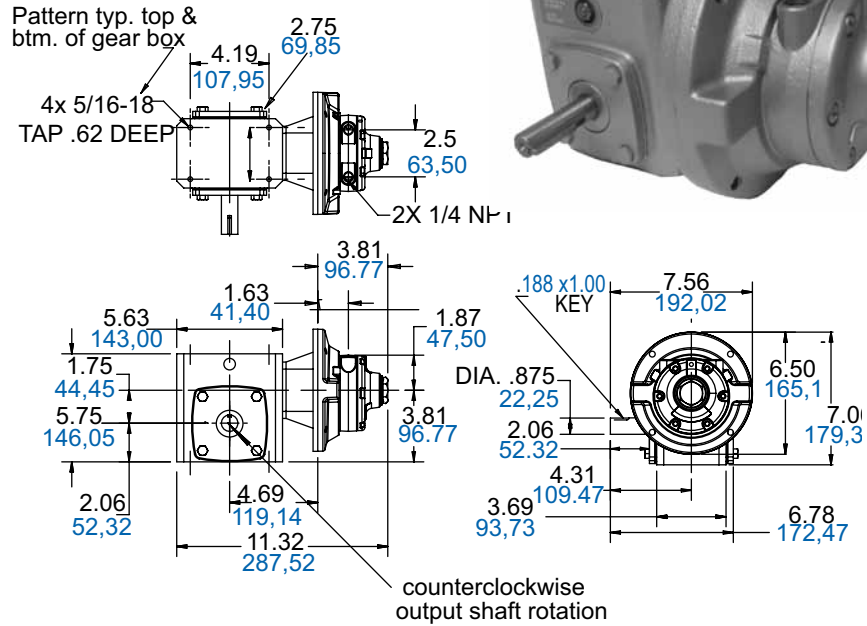

Air Consumption vs. Speed

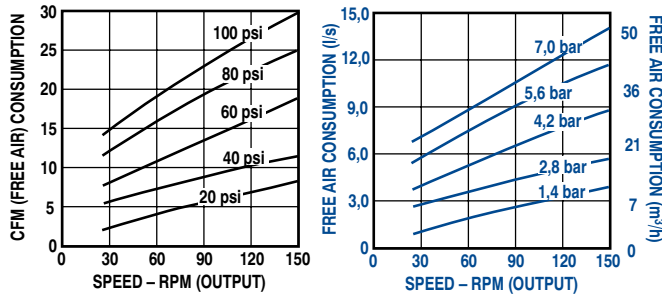

Output Power vs. Speed

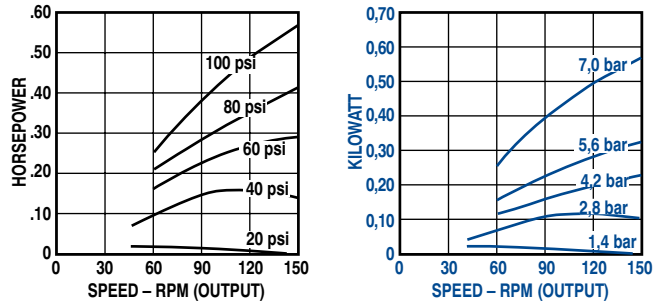

Torque vs. Speed

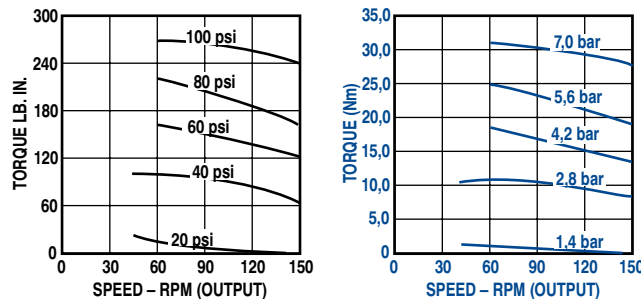

Model

4AM-RV-75-GR20 (4 Vanes, Reversible)

Net wt. 28 lbs (12,6 kg)

FEATURES

- 10:1 gear reducer
- Face and foot mounting
- Horizontal or shaft down operation
- Metal muffler AC980 adds 2" height when installed
-  II 2 GD c T4

RECOMMENDED

- Filter AH103F
- Regulator AH104R
- Gauge AA806
- Lubricator AH105L
- Oil AD220 – 1 quart (.94 litres)
- Repair kit K205 (Air motor only)

Max. allowable end thrust with 0 overhung load ranges from 200 lbs (90,0 kg) at 300 rpm to 800 lbs (360,0 kg) at 30 rpm. Max. overhung load with 0 end thrust ranges from 200 lbs (90,0 kg) at 300 rpm to 600 lbs (270,0 kg) at 30 rpm. Max. recommended pressures to 80 psi (5,6 bar).



Product Dimensions (inches, mm)

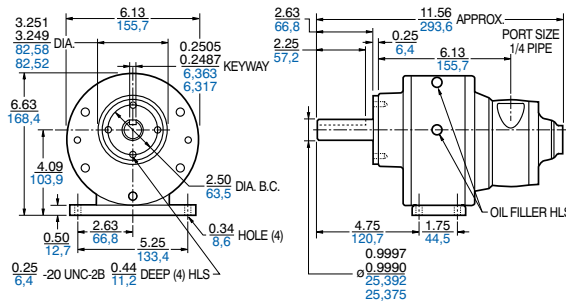

Output Power vs. Speed

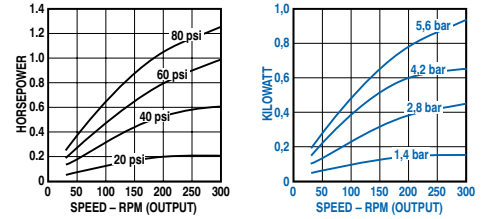

Torque vs. Speed

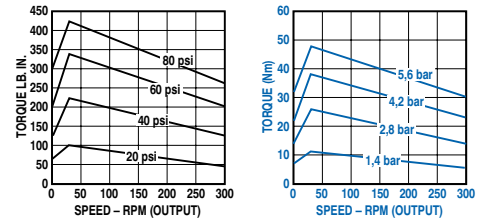

Air Consumption vs. Speed

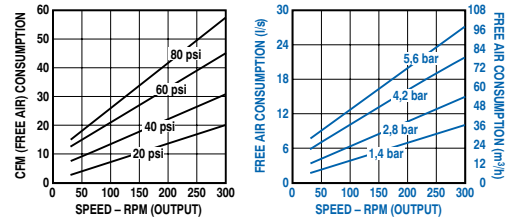

MODEL

4AM-RV-75-GR25 (4 Vanes, Reversible)

Net wt. 28 lbs (12,6 kg)

FEATURES

- 15:1 gear reducer
- Face, foot mounting
- Horizontal or shaft down operation
- Metal muffler AC980 adds 2" height when installed
-  II 2 GD c T4

RECOMMENDED

- Filter AH103F
- Regulator AH104R
- Gauge AA806
- Lubricator AH105L
- Oil AD220 – 1 quart (.94 litres)
- Repair kit K205 (Air motor only)

Max. allowable end thrust with 0 overhung load ranges from 250 lbs (112,5 kg) at 200 rpm to 800 lbs (360,0 kg) at 20 rpm. Max. overhung load with 0 end thrust ranges from 200 lbs (90,0 kg) at 200 rpm to 600 lbs (270,0 kg) at 20 rpm. Max. recommended pressures to 80 psi (5,6 bar).



Product Dimensions (inches, mm)

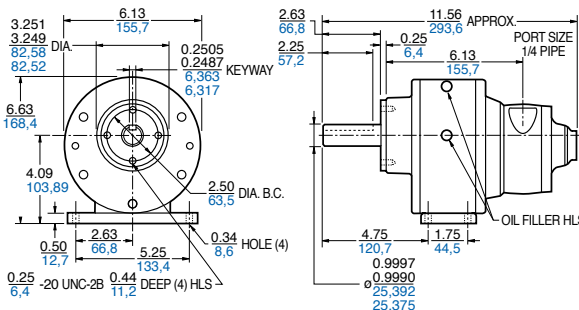

Output Power vs. Speed

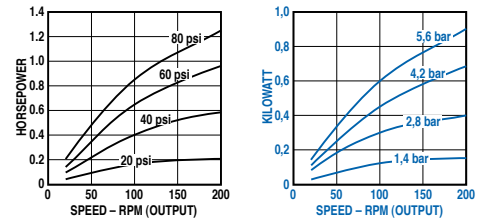

Torque vs. Speed

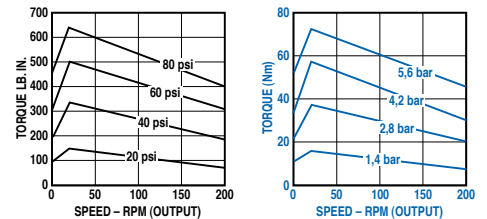

Air Consumption vs. Speed

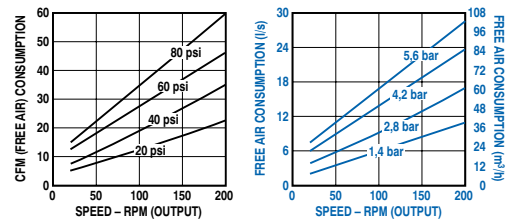

Model

4AM-70C-CB60

(8 Vanes, Reversible)

Net wt. for standard configuration
60 lbs (27,0 kg)

FEATURES

- 60:1 gear reducer
- Base mounting
- Optional mountings and shaft locations available
- Metal muffler AC980 adds 2" height when installed

RECOMMENDED

- Filter AH103F
- Regulator AH104R
- Gauge AA806
- Lubricator AH105L
- Oil AD220 – 1 quart (.94 litres)
- Repair kit K280A (Air motor only)

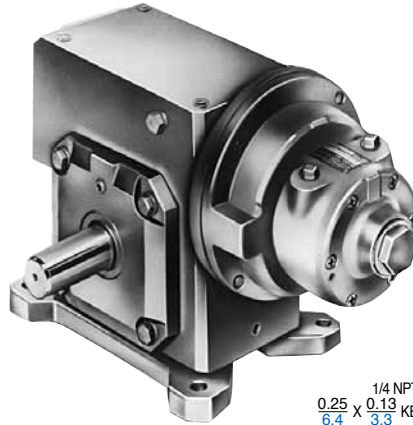

Max. allowable end thrust with 0 overhung load is 3545 lbs (1595,3 kg) at 10 rpm to 2134 lbs (960,3 kg) at 50 rpm. Max. overhung load on output shaft with 0 end thrust 1601 lbs (720,5 kg).

Product Dimensions (inches, mm)

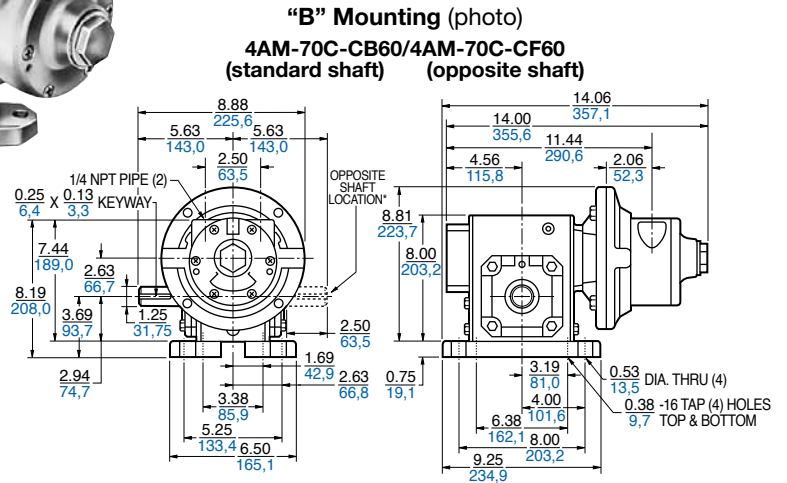

Output Power vs. Speed

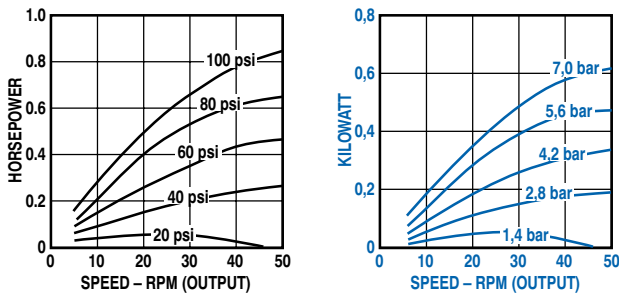

Torque vs. Speed

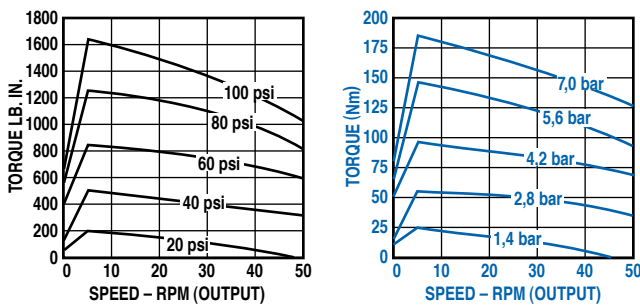

Air Consumption vs. Speed

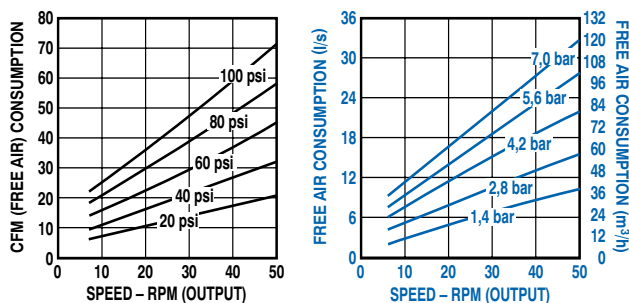

"C" Mounting

4AM-70C-CC60/4AM-70C-CG60
(standard shaft) (opposite shaft)

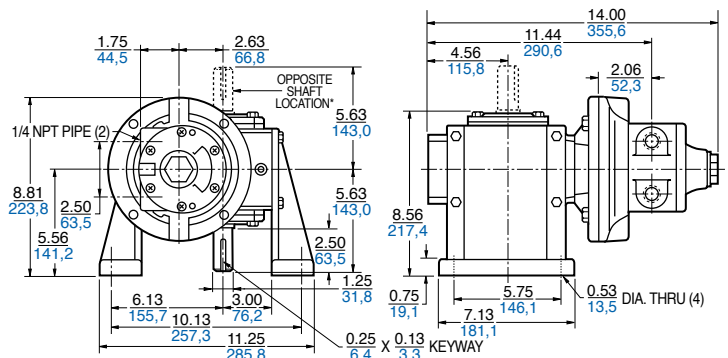

"D" Mounting

4AM-70C-CD60/4AM-70C-CH60
(standard shaft) (opposite shaft)

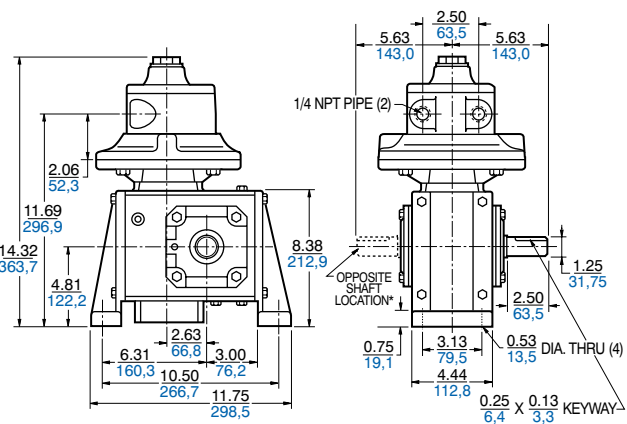

Model

6AM-22A-CB10

(8 Vanes, Reversible)

Net wt. for standard configuration
56 lbs (25,2 kg)

FEATURES

- 10:1 gear reducer
- Base mounting
- Optional mountings and shaft locations available
- Muffler AC990 (not shown)

RECOMMENDED

- Filter AH106F
- Regulator AH107R
- Gauge AA806
- Lubricator AH108L
- Oil AD220 – 1 quart (.94 litres)
- Repair kit K281 (Air motor only)

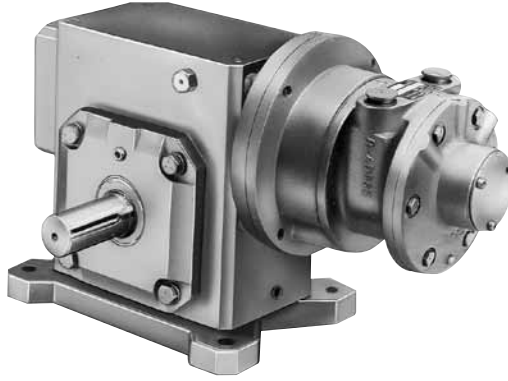

Max. allowable end thrust with 0 overhung load is 1640 lbs (738,0 kg) at 60 rpm to 923 lbs (415,4 kg) at 300 rpm. Max. overhung load on output shaft with 0 end thrust 1601 lbs (720,5 kg).

Product Dimensions (inches, mm)

“B” Mounting (photo)
6AM-22A-CB10 / 6AM-22A-CF10
(standard shaft) (opposite shaft)

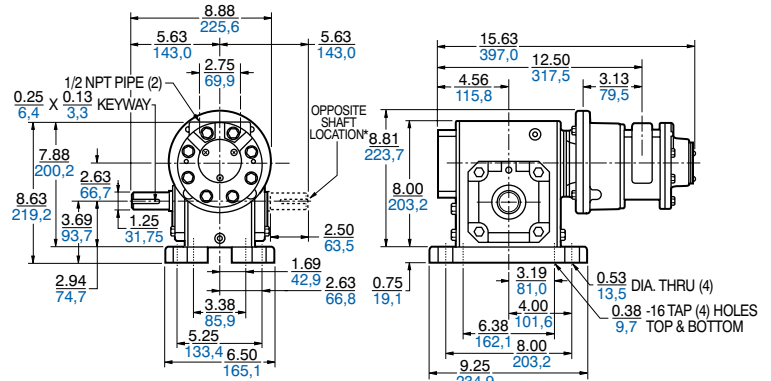

“C” Mounting

6AM-22A-CC10/6AM-22A-CG10
(standard shaft) (opposite shaft)

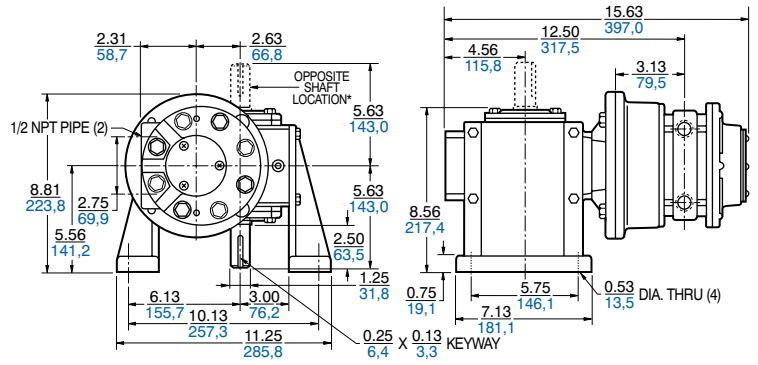

“D” Mounting

6AM-22A-CD10 / *6AM-22A-CH10
(standard shaft) (opposite shaft)

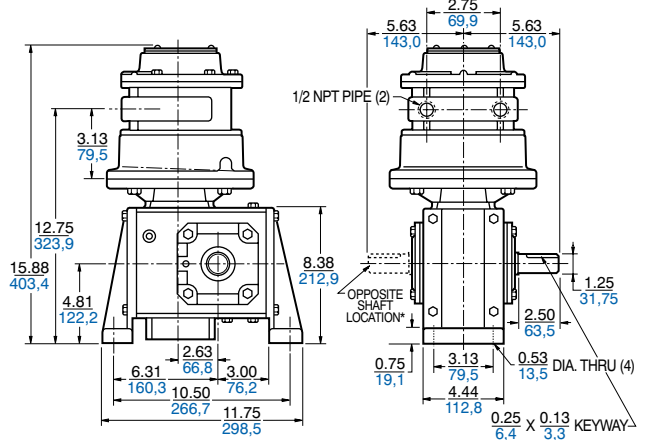

Output Power vs. Speed

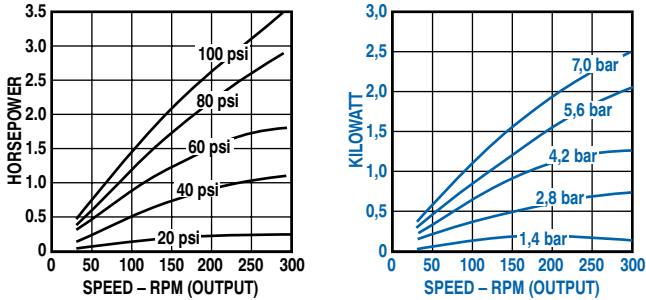

Torque vs. Speed

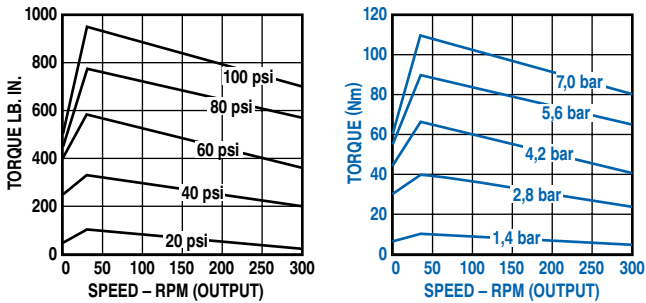

Air Consumption vs. Speed

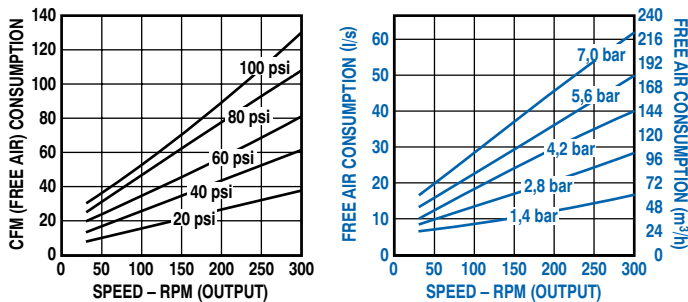

Model

6AM-22A-DB20

(8 Vanes, Reversible)

Net wt. for standard configuration
100 lbs (45,0 kg)

FEATURES

- 20:1 gear reducer
- Base mounting
- Optional mountings and shaft locations available
- Muffler AC990 (not shown)

RECOMMENDED

- Filter AH106F
- Regulator AH107R
- Gauge AA806
- Lubricator AH108L
- Oil AD220 – 1 quart (.94 litres)
- Repair kit K281 (Air motor only)

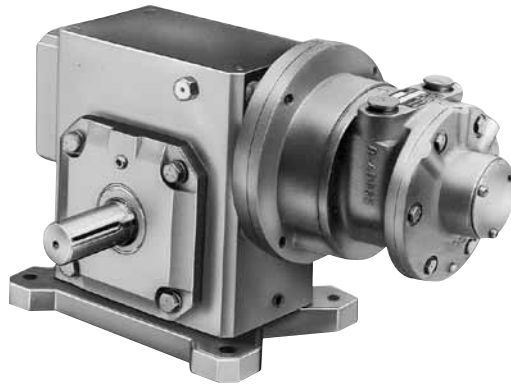

Max. allowable end thrust with 0 overhung load is 3552 lbs (1598,4 kg) at 30 rpm to 2154 lbs (969,3 kg) at 150 rpm.
Max. overhung load on output shaft with 0 end thrust 2857 lbs (1285,7 kg).

Product Dimensions (inches, mm)

“B” Mounting (photo)

6AM-22A-DB20/6AM-22A-DF20
(standard shaft) (opposite shaft)

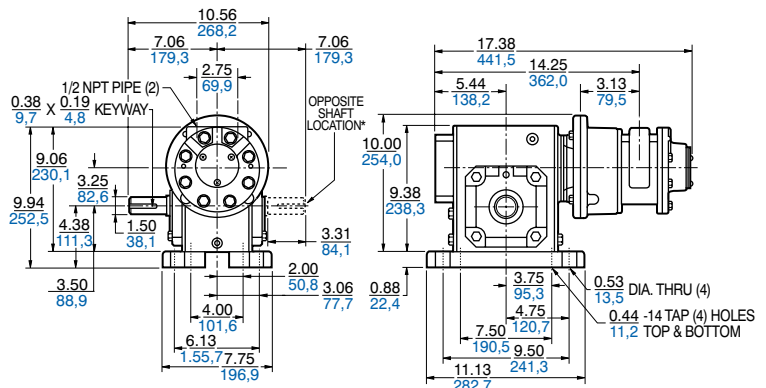

“C” Mounting

6AM-22A-DC20/6AM-22A-DG20
(standard shaft) (opposite shaft)

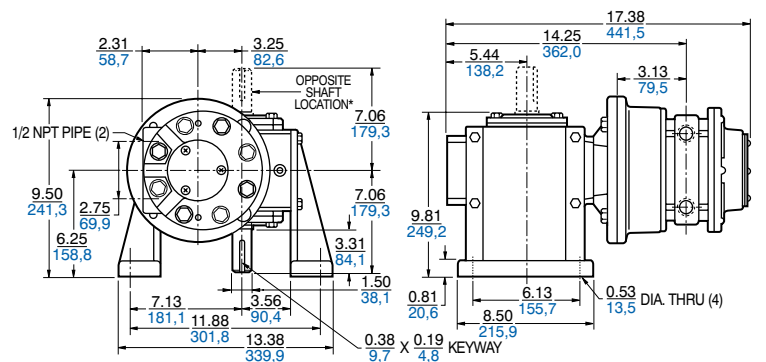

“D” Mounting

6AM-22A-DD20/6AM-22A-DH20
(standard shaft) (opposite shaft)

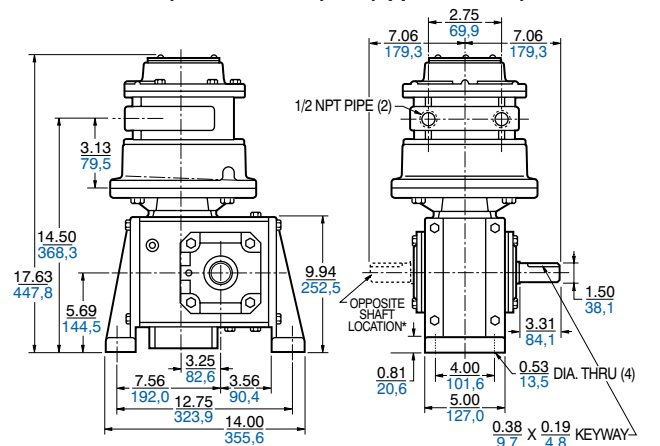

Output Power vs. Speed

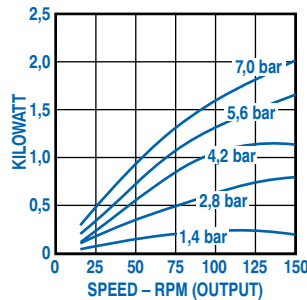
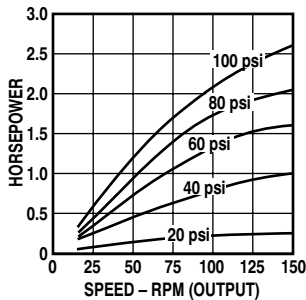

Torque vs. Speed

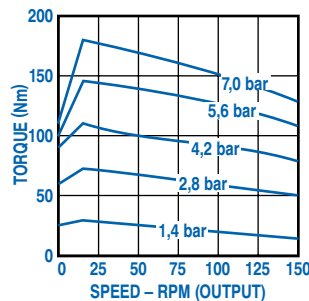
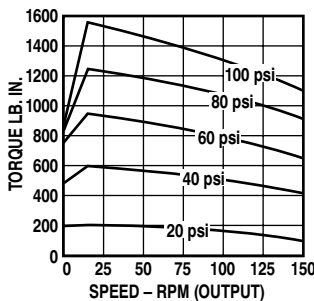

Air Consumption vs. Speed

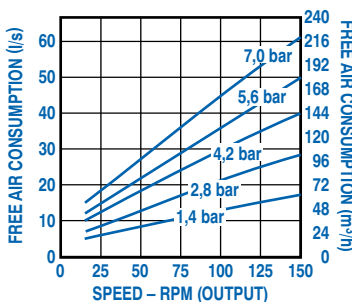
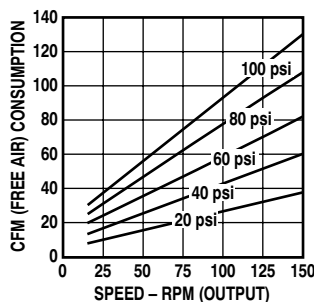

Model

6AM-22A-GB40

(8 Vanes, Reversible)

Net wt. for standard configuration
104 lbs (46,8 kg)

FEATURES

- 40:1 gear reducer
- Base mounting
- Optional mountings and shaft locations available
- Muffler AC990 (not shown)

RECOMMENDED

- Filter AH106F
- Regulator AH107R
- Gauge AA806
- Lubricator AH108L
- Oil AD220 – 1 quart (.94 litres)
- Repair kit K281 (Air motor only)

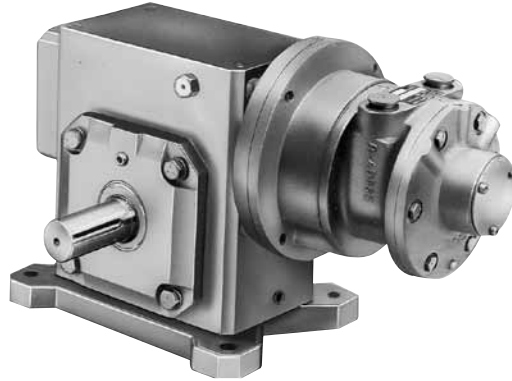

Max. allowable end thrust with 0 overhung load is 3552 lbs (1598,4 kg) at 30 rpm to 2154 lbs (969,3 kg) at 75 rpm. Max. overhung load on output shaft with 0 end thrust 2857 lbs (1285,7 kg).

Product Dimensions (inches, mm)

“B” Mounting (photo)
6AM-22A-GB40/6AM-22A-GF40
(standard shaft) (opposite shaft)

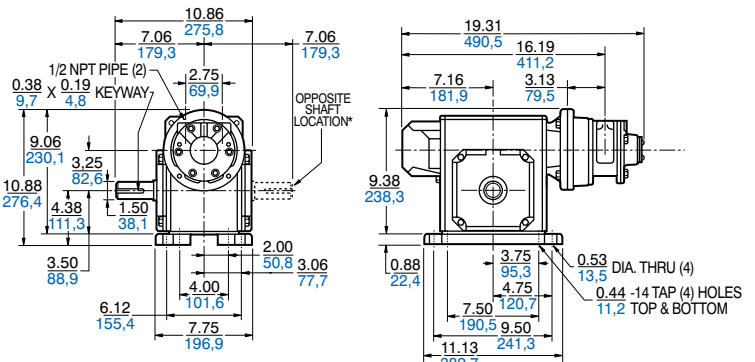

“C” Mounting
6AM-22A-GC40/6AM-22A-GG40
(standard shaft) (opposite shaft)

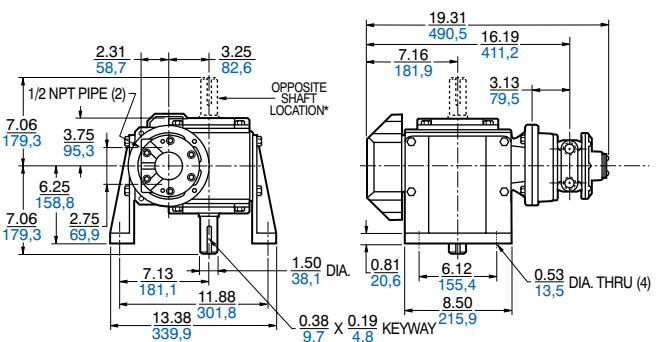

Output Power vs. Speed

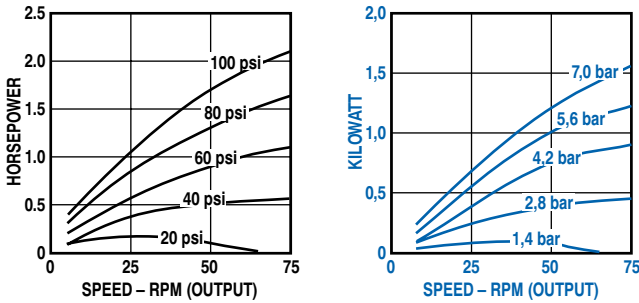

Torque vs. Speed

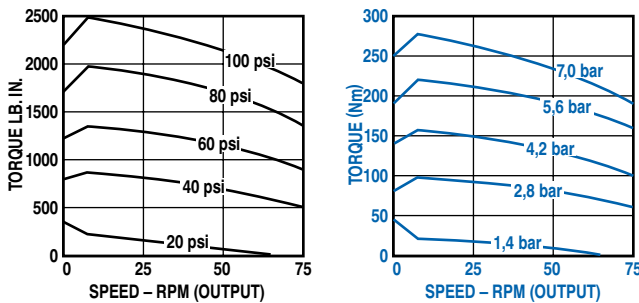

Air Consumption vs. Speed

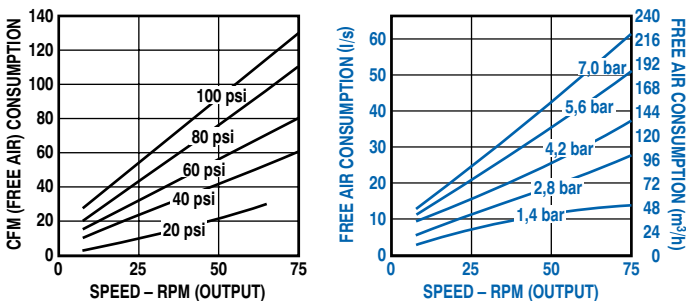

Model

8AM-32A-FB20 (8 Vanes, Reversible)

Net wt. for standard configuration
111 lbs (50,0 kg)

FEATURES

- 20:1 gear reducer
- Base mounting
- Optional mountings and shaft locations available
- Muffler AC990 (not shown)

RECOMMENDED

- Filter AH106F
- Regulator AH107R
- Gauge AA806
- Lubricator AH108L
- Muffler AG600 (above 1,000 rpm)
- Oil AD220 – 1 quart (.94 litres)
- Repair kit K282 (Air motor only)

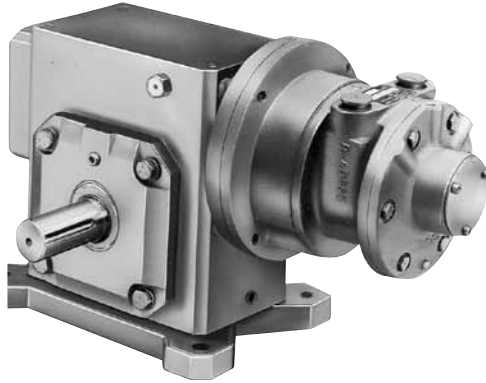

Max. allowable end thrust with 0 overhung load is 3552 lbs (1598,4 kg) at 30 rpm to 2154 lbs (969,3 kg) at 125 rpm. Max. overhung load on output shaft with 0 end thrust 2857 lbs (1285,7 kg).

Product Dimensions (inches, mm)

“B” Mounting (photo) 8AM-32A-FB20/8AM-32A-FF20 (standard shaft) (opposite shaft)

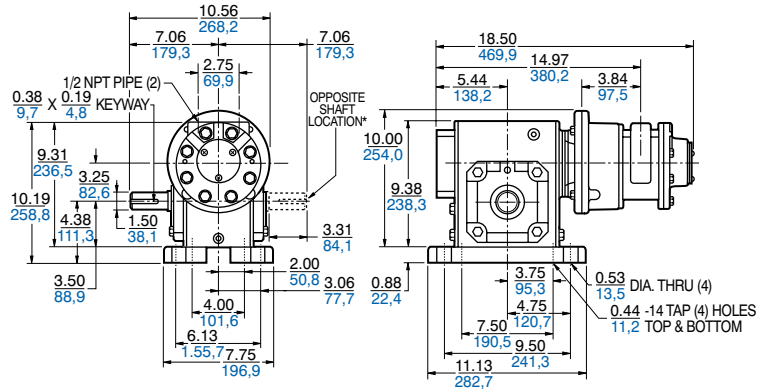

“C” Mounting 8AM-32A-FC20

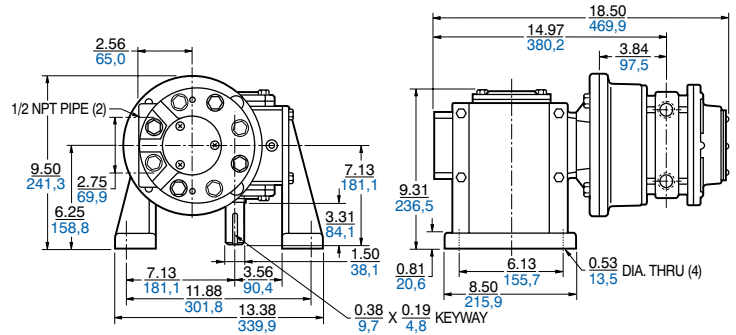

“D” Mounting 8AM-32A-FD20

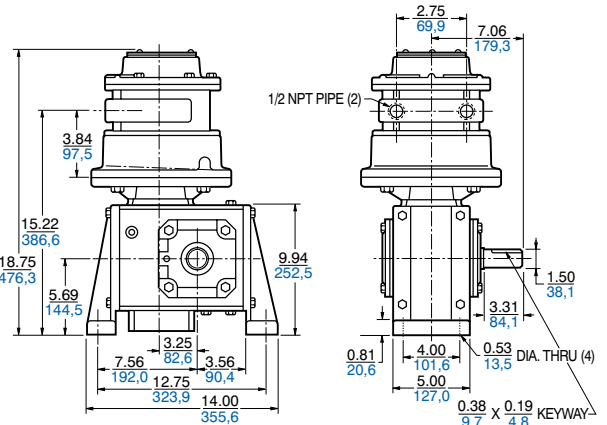

Output Power vs. Speed

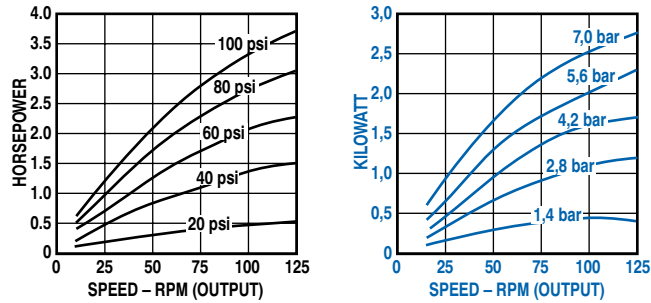

Torque vs. Speed

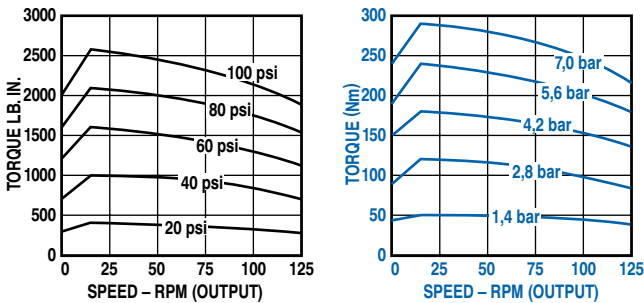

Air Consumption vs. Speed

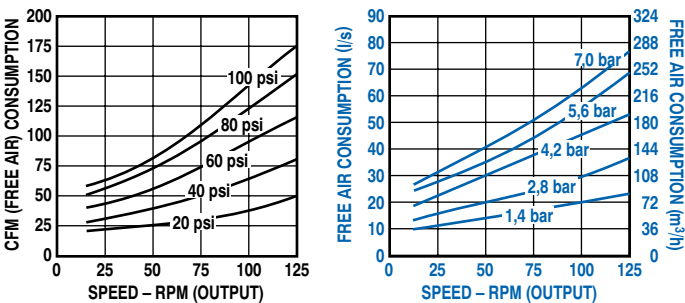

Model

16AM-13-HB20

(6 Vanes, Reversible)

Net wt. for standard configuration
163 lbs (73,4 kg)

FEATURES

- 20:1 gear reducer
- Base mounting
- Optional mountings and shaft locations available

RECOMMENDED

- Filter AH109F
- Regulator AH110R
- Gauge AA806
- Lubricator AH111L
- Muffler AG601
- Oil AD220 – 1 quart (.94 litres)
- Repair kit K213 (Air motor only)

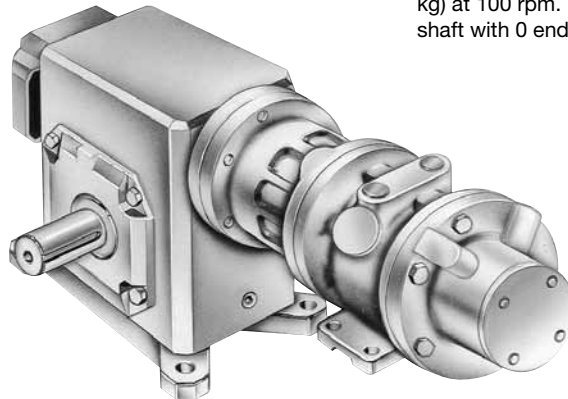

Max. allowable end thrust with 0 overhung load is 3552 lbs (1598,4 kg) at 30 rpm to 2154 lbs (969,3 kg) at 100 rpm. Max. overhung load on output shaft with 0 end thrust 2857 lbs (1285,7 kg).

Product Dimensions (inches, mm)

“B” Mounting (photo)

16AM-13-HB20/16AM-13-HF20
(standard shaft) (opposite shaft)

Output Power vs. Speed

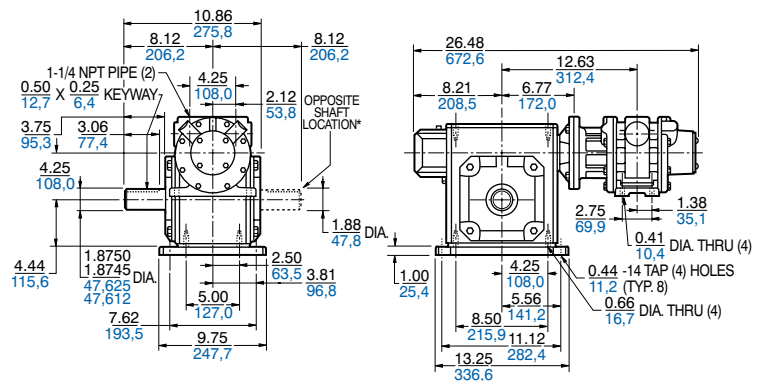
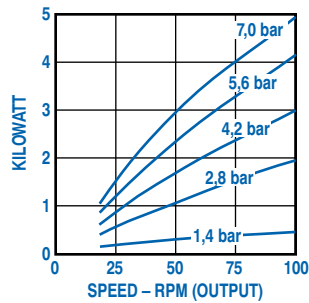
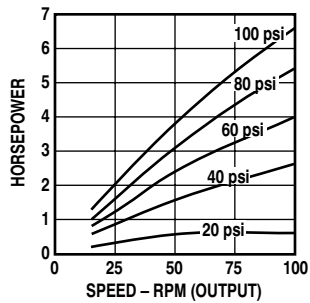

Torque vs. Speed

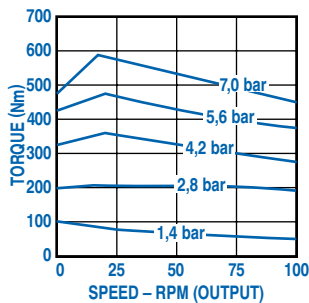
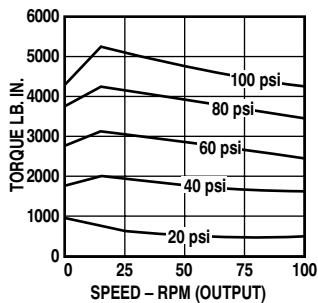

“C” Mounting

16AM-13-HC20/*16AM-13-HG20
(standard shaft) (opposite shaft)

Air Consumption vs. Speed

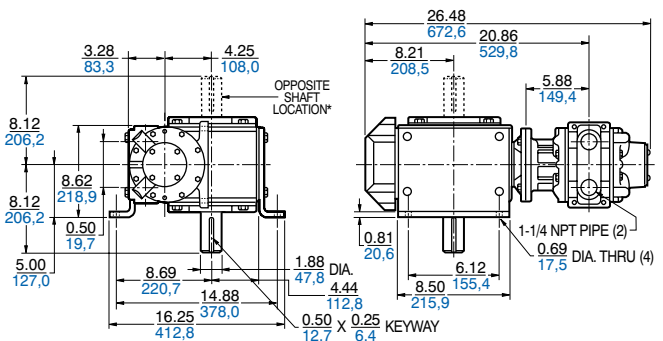
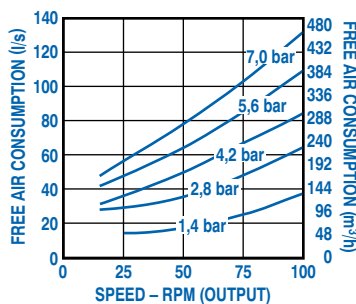
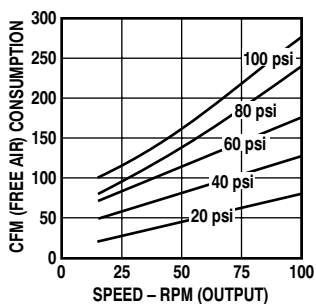

FILTERS

Gast Part Number	Port Size	Flow* SCFM	Used With	Dimensions - in. (mm)		
				A	B	C
+AH100F	1/8" NPTF	18	1AM/1UP/NL22	1.63 (41,4)	3.25 (82,6)	0.38 (9,7)
+AH103F	1/4" NPTF	50	2AM/4AM/NL32/NL42	2.75 (69,9)	5.84 (148,3)	0.69 (17,5)
+AH106F	1/2" NPTF	117	6AM/8AM/NL52	3.91 (99,3)	6.69 (169,9)	0.67 (17,0)
+AH109F	1" NPTF	365	16AM	4.75 (120,7)	10.44 (265,2)	1.25 (31,8)

*SCFM = Standard cubic feet per minute at 100 psi inlet and 5 psi pressure drop.

+Metal Bowl

REGULATORS

Gast Part Number	Port Size	Flow* SCFM	Used With	Dimensions - in. (mm)		
				A	B	C
AH101R	1/8" NPTF	11	1AM/1UP/NL22	1.63 (41,4)	2.38 (60,5)	0.38 (9,7)
AH104R	1/4" NPTF	50	2AM/4AM/NL32/NL42	2.44 (62,0)	4.00 (101,6)	1.54 (39,1)
AH107R	1/2" NPTF	130	6AM/8AM/NL52	3.50 (88,9)	5.36 (136,1)	1.50 (38,1)
AH110R	1" NPTF	360	16AM	4.25 (108,0)	5.69 (144,5)	2.38 (60,5)

*SCFM = Standard cubic feet per minute at 100 psi inlet, 80 psi secondary setting and 10 psi pressure drop.

LUBRICATORS

Gast Part Number	Port Size	Flow* SCFM	Used With	Dimensions - in. (mm)		
				A	B	C
+AH102L	1/8" NPTF	13	1AM/1UP	1.77 (45,0)	3.37 (85,6)	1.76 (44,7)
+AH105L	1/4" NPTF	20	2AM/4AM	2.56 (65,0)	5.75 (146,1)	1.85 (47,0)
+AH108L	1/2" NPTF	90	6AM and 8AM	3.91 (99,3)	6.69 (169,9)	1.88 (47,8)
+AH111L	1" NPTF	290	16AM	4.50 (114,3)	10.24 (260,1)	2.22 (56,4)

*SCFM = Standard cubic feet per minute at 100 psi inlet and 5 psi pressure drop.

+Metal Bowl

SPECIFICATIONS

Duty levels and applications may require different FRL's than recommended.

FILTER ELEMENT:

- 5 micron

PORT THREADS:

- All ports NPTF

GAUGE PORTS:

- Regulator Two ports – 1/4" NPTF, can be used as additional outlet ports, full flow 1/4", 1/8" NPTF for AH101R model.

PRESSURE RATING:

- Regulator Maximum primary pressure: 250 psi (17 bar)
- Secondary pressure range: Standard 2-125 psi (.14 to 8.6 bar)
- Temperature rating: -10 °F to 175 °F (-23 °C to 80 °C)

PRESSURE AND TEMPERATURE RATINGS:

- Polycarbonate Bowls
200 psi at 120 °F (14 bar at 49 °C) or less
100 psi at 175 °F (7 bar at 80 °C) or less

METAL BOWLS:

- 250 psi at 175 °F (17 bar at 80 °C) or less

BOWLS:

- Metal bowl

BOWL CAPACITY:

- 1 ounce for 1/8" model
- 5 ounce for 1/4" model
- 8 ounce for 1/2" model
- 32 ounce for 1" model

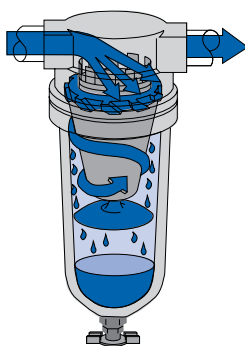

A filter helps ensure efficient operation by removing solid and liquid contaminants before they enter the air motor.

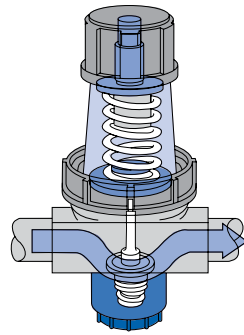
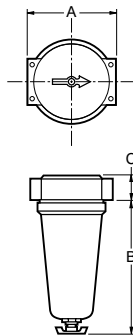

An air pressure regulator is necessary in most air motor applications to maintain a constant pressure regardless of the rise and fall of line pressure.

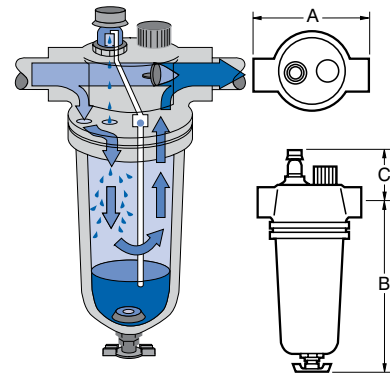
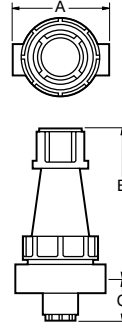

Mist lubricators provide uniform lubrication for the traditional lubricated style air motor. This results in reduced friction, extending the life of moving parts.

